

October, 2009
ML0015 Document Revision B
© 2009 by Bitronics, LLC

No. XTWIE1A Watt/VAR Phase A Amp Meter
No. XTWIE2A Watt/VAR Phase B Volt Meter
No. XTWIE2A-NS0004 Watt/VAR Phase B Sec. Volt Meter

Firmware Version 1.50 and Later
Includes information on CI1 Option (1A input)
Includes information on VD4A and VA4 Optional Power Supplies

TABLE OF CONTENTS

TABLE OF CONTENTS	i
CERTIFICATION	ii
INSTALLATION AND MAINTENANCE	ii
WARRANTY AND ASSISTANCE	ii
COPYRIGHT	ii
1.0 DESCRIPTION	1
1.1 Introduction.....	1
1.2 Features	1
1.3 Specifications	2
2.0 PRINCIPLES OF OPERATION	3
2.1 Modular Construction	3
2.2 Input Signal Connections	3
2.3 Current and Potential Transformer Board (CT/PT Board)	4
2.4 Power Supply Board (PS Board)	4
2.5 Analog Processing Board (AP Board)	5
2.6 Host Micro Board (MCU Board)	6
2.7 LED Display Board (LED Board)	6
3.0 INSTALLATION	7
3.1 Initial Inspection	7
3.2 Power Requirements	7
3.3 Overcurrent Protection	7
3.4 Mains Disconnect	7
3.5 Instrument Mounting	7
3.6 Surge Protection	8
4.0 FIELD ADJUSTMENTS	9
4.1 Rescaling	9
4.2 Calibration	13
4.3 Self Test Modes	13
4.4 Cleaning	13
4.5 Electronics Module Removal	16
5.0 QUESTIONS AND ANSWERS	17
APPENDIX - CONNECTION DIAGRAMS	18

CERTIFICATION

Bitronics LLC certifies that the calibration of our products is based on measurements using equipment whose calibration is traceable to the United States National Institute of Standards Technology (NIST).

COPYRIGHT

This Manual is copyrighted and all rights are reserved. The distribution and sale of this manual are intended for the use of the original purchaser or his agents. This document may not, in whole or part, be copied, photocopied, reproduced, translated or reduced to any electronic medium or machine-readable form without prior consent of Bitronics LLC., except for use by the original purchaser.

INSTALLATION AND MAINTENANCE

Bitronics' products are designed for ease of installation and maintenance. As with any product of this nature, however, such installation and maintenance can present electrical hazards and should only be performed by properly trained and qualified personnel. If the equipment is used in a manner not specified by Bitronics, the protection provided by the equipment may be impaired.

WARRANTY AND ASSISTANCE

This product is warranted against defects in materials and workmanship for a period of thirty-six (36) months from the date of their original shipment from the factory. Products repaired at the factory are likewise warranted for eighteen (18) months from the date the repaired product is shipped, or for the remainder of the product's original warranty, whichever is greater. Obligation under this warranty is limited to repairing or replacing, at our designated facility, any part or parts that our examination shows to be defective. Warranties only apply to products subject to normal use and service. There are no warranties, obligations, liabilities for consequential damages, or other liabilities on the part of Bitronics LLC except this warranty covering the repair of defective materials. The warranties of merchantability and fitness for a particular purpose are expressly excluded.

For assistance, contact Bitronics LLC at:

Telephone: 610.997.5100
Fax: 610.997.5450
Email: bitronics@novatechps.com
Website: www.novatechweb.com/bitronics

Shipping:
261 Brodhead Road
Bethlehem, PA 18017-8698 USA

1.0 DESCRIPTION

1.1 Introduction

Current and voltage, as well as real and reactive power are essential quantities which must be measured accurately in order to optimize the control and delivery of electric power. State of the art technology makes it possible to measure these functions very accurately, over a wide range of input signals. The Bitronics Three Phase MULTIFUNCTION Meters are rugged electronic instruments designed for utility and industrial applications requiring reliable, precise measurements of three-phase power systems. True RMS measurements are standard, and include harmonics beyond the 7th harmonic in both the current and voltage inputs, resulting in accurate measurements, even with distorted waveforms. The use of "State-of the Art" microprocessor technology assures digital accuracy and repeatability across the entire range of input signal levels. MULTIFUNCTION meters are modular in design, with push-button rescaling to display primary values when using any standard current and voltage transformer. Rescaling can be done in the field, in a matter of minutes, without removing the instrument from the panel or the need for any calibration equipment. Physical dimensions are the standard 4" round case with an overall length of 6.5 inches.

1.2 Features

- * Simultaneously displays three-phase Watts, Vars, & true RMS Amps for Phase-A (XTWIE1) or true RMS Volts for Phase-B (XTWIE2). NS0004 Option on XTWIE2A displays Phase-B voltage in secondary units
- * Push-button rescaling in the field accommodates all ANSI CT and PT ratios. Displays primary or secondary values. (Non-standard ratios available, consult factory.)
- * Field-changeable modular design for easy maintenance.
- * Single push button selects CT/PT setting, and also resets the microprocessor.
- * Non-volatile memory backup of CT/PT settings. No batteries are needed.
- * Rugged metal housing fits standard 4-inch round cutout.
- * True RMS measurements are standard.
- * 4 digit high efficiency LEDs for easy reading.
- * Three 0-1mA DC current outputs for each phase, allowing connection to SCADA or other equipment.
- * Watchdog timer maximizes system reliability.

1.3 Specifications

Input Signals

Amperes: 0 to 5^{*} A ac nominal, three phase, with continuous overload to 10^{*} A ac (15^{*} A ac for Neutral Current), 400A ac for 2 seconds. 1500V ac isolation, minimum.

Volts: 0 to 150 ac nominal, three phase. 500V ac isolation, minimum.

Signal Burden

Amperes: 4mV ac at 5A ac input (0.02 VA).

Volts: 200k ohms (0.6mA ac at 120V ac input - 0.072 VA).

Display: 0000 to 9999 (VOLTs or AMPs).
-999 to 000 to 999 (WATTs & VARs).
CT/PT Ratio sets decimal points.

Scaling: User selectable using internal CT/PT tables.

Accuracy: 0.25% Class (ANSI Std 460-1988).

Signal Frequency: 50Hz to 400Hz (Including Harmonics).

Energy Registers: 0-1mA into 10K ohms or less; 0.4 % ripple p-p or less.
Calibrated at 5^{*} A (ammeter), 150V (voltmeter) or 1500^{*} Watts (VARs) (500^{*}W per Element) at meter input. Overload to 2mA into 5K ohms or less.

Power Requirements:

115 V ac +/-20%, 6VA (standard)
VA4: 230 V ac +/-20%, 6VA (optional)
VD4A: Universal 55-200 V ac or 20-280 V dc, 6 Watts (optional)

Fuse: 1.5 Ampere, non-time delay (M) fuse, UL listed located in the ungrounded (hot) side of the line, external to meter.

Temperature: -30C to 70C. Humidity: 0-95 % non-condensing

Installation Category: IC III (Distribution Level), Pollution Degree 2

Weight: 2.5 pounds (1.14 kilograms)

* - When C11 Option (1Amp Input) is installed, divide this value by 5

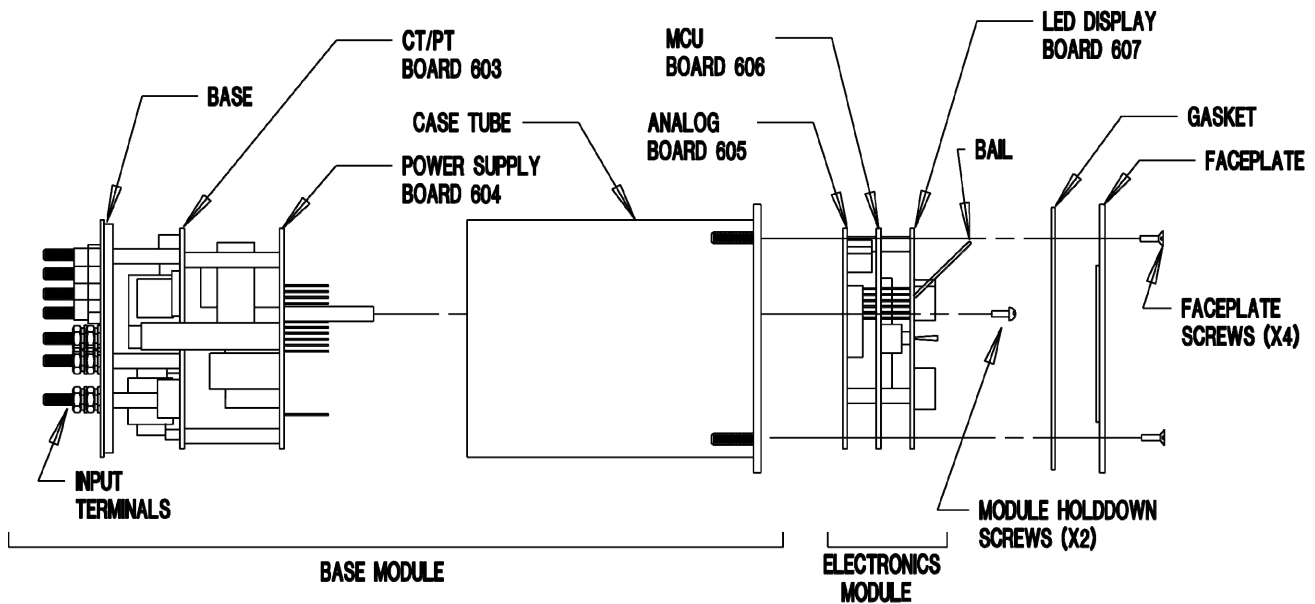

Figure 1 – MULTIFUNCTION Meter Exploded View

2.0 PRINCIPLES OF OPERATION

2.1 Modular Construction

The Bitronics MULTIFUNCTION Meters are composed of two major modules, as shown in the exploded view of the meter (Figure 1). The BASE MODULE consists of the case tube, the back panel, the Output Connector Board, the Current Transformer & Potential Transformer Board and the Power Supply Board. The Base Module contains primarily passive components (transformers, connectors, etc.) and cannot be serviced without removal from the panel. The ELECTRONICS MODULE consists of the Analog Processing Board, Microcontroller Board, and the LED Display Board. Ninety percent of the active electronics (Integrated Circuits, diodes, etc.) are contained within the three boards comprising the Electronics Module. This module can easily be removed for maintenance without the need to remove the meter from the panel, or to remove the meter from service (see section 4.4). Detailed descriptions of each of the boards can be found in the following sections.

2.2 Input Signal Connections

The MULTIFUNCTION Meters have six independent signal inputs; one current and one voltage for each phase being measured. Current and voltage signals are connected directly to #10-32 brass studs on the rear panel of the instrument. **WARNING - DO NOT** overtighten the nuts on the input connections, **HAND** tighten with a standard nutdriver, 12 inch-pounds is recommended, **MAXIMUM** torque is 15 inch-pounds. The instrument can be connected directly to current

transformer (CT) or potential transformer (PT) circuits. The impedance at the MultiFunction terminals is nearly a short circuit (2 milliohms) for ammeters and high impedance (> 100 K-ohms) for voltmeters. These ideal impedances provide low burden loads for the CT or PT circuits supplying the signals. The polarity of the applied signals is important to the function of the instrument, and the signal terminals are labeled LO or HI to aid in wiring the units into substation or control panels. A wiring diagram is also provided in the form of a decal on the side of the meter. Grounding of PT & CT signals per ANSI/IEEE C57.13.3-1983 is recommended.

Power is applied to two #10-32 brass studs, also located on the rear cover of the instrument. **WARNING - DO NOT** overtighten the nuts on the input connections, **HAND** tighten with a standard nutdriver, 12 inch-pounds is recommended, **MAXIMUM** torque is 15 inch-pounds. Because of the solid state design, the total load required to operate the unit is only six WATTS. It is therefore possible to power the Watt/VAR Meter with AC or DC station power or an auxiliary PT, provided the voltage remains above 90 volts. Units are normally shipped configured with a 115V ac, however they may be special ordered with a 230V ac or Universal (AC/DC) supply.

2.3 Current and Potential Transformer Board (CT/PT Board)

The current and potential transformer (CT/PT) board contains secondary transformers which provide electrical isolation for each of the signal input channels. Current from the current terminals flows through a silver-soldered shunt of negligible resistance to assure that the user's external CT circuit can never open-circuit, even under extreme fault conditions. Potential voltages are carried through 10-32 studs directly to the CT/PT board to guarantee reliable connections to the high-impedance secondary transformer circuits. The use of transformer isolation on all input leads provides excellent isolation (>1500 V ac) between the current inputs and any outputs, and 5000V ac between PT inputs and any output.

2.4 Power Supply Board (PS Board)

The power supply circuit is a conservative, conventional design. Low drop rectifiers and a low drop-out solid state regulator minimize internal power dissipation. Filter capacitors are operated at a fraction of their voltage and temperature ratings, and should provide years of trouble-free service under extreme environmental conditions.

The XTWIE_x Family is also available with an optional Universal Power Supply. The universal power supply is a high-efficiency, high-frequency switching power supply with integrated overcurrent protection. Power from the input terminals is conducted to a full-wave bridge rectifier and capacitor to convert AC power inputs to DC. DC power inputs are unaffected by the bridge rectifier. Input polarities are marked for reference only. The DC voltage across the filter capacitor is alternately connected and disconnected to the isolation/power transformer at a rate of about 60kHz, by a pulse-width controller. A separate feedback winding on the power transformer provides a signal which is used by the controller to vary the time that the transformer is connected to the power source. This allows the supply to provide a relatively constant output voltage over a wide range of input voltages and output loads. The output of the switching supply is then post regulated by a low-drop linear regulator to provide precise supply voltage control under all conditions.

Bitronics MULTIFUNCTION instruments provide for complete interchangeability among signal processing and display modules. Compensation for normal variations in input circuits is achieved by storing calibration constants in a non-volatile memory (EEPROM) which resides on the PS board. These constants are factory-programmed to provide identical signal gain (attenuation) in each of the six isolated signal input paths. The CT and PT settings for scaling the display to the user's CTs and PTs are also stored in this EEPROM. Checksums are incorporated into the EEPROM which are read periodically by the microcontroller to check the integrity of the calibration constants and the CT and PT setting (See section 4.3).

2.5 Analog Processing Board (AP Board)

The first function of Analog Processing board is to sample and digitize the low level AC signals provided by the CT/PT board, and to provide a digital number to the microcontroller (MCU) for further processing. Signal processing begins with the low level AC signal supplied from the CT/PT board which is about one volt ac RMS for a full scale input signal. Pure sine wave inputs or complex, distorted, periodic waveforms are handled equally well - a major advantage when computing true RMS values for unknown current and voltage waveforms. This design frees the user from concern about errors which will otherwise occur during the measurement of distorted waveforms with non-true RMS instruments. Phases A,B and C are sampled in succession, providing the MCU with instantaneous measurements of all voltage or current inputs. Samples are accumulated for 0.5 seconds, at which time the MCU calculates the true RMS values for each phase. The RMS values for each phase are averaged with a sliding window for 2.5 seconds, in order to eliminate excessive jitter in the display. Zero offset is also adjusted for each signal channel every 0.5 seconds by the MCU. Calibration constants stored in both the Power Supply EEPROM and the EEPROM located on this board provide drift-free calibration, and complete interchangeability of Analog Processing boards. Checksums are incorporated into both EEPROMs which are read periodically by the microcontroller to check the integrity of the calibration constants and the CT or PT setting (See section 4.3). A "Master Gain" trimpot is also located on the AP board to provide the user with fine tuning capability if it is necessary to match other devices on the power system. Once the true RMS values have been calculated, the MCU scales the values by the external PT and CT ratios which have been selected by the user, and displays the values.

A second function of the AP board is to provide the three optional 0-1mA transducer outputs. This is accomplished with three 12-bit digital to analog converters (DAC), one for each of the three output channels. Constants stored in the EEPROM on the analog board are read by the MCU and used to compensate for gain and offset of each output channel. This technique provides stable calibrations for these outputs. Additional circuitry converts the output of each DAC to the 0-1mA current. This additional circuitry is powered from a +15V dc and a -15V dc supply also located on the AP module. The outputs have a 10V dc compliance, and can drive a 1.0mA into a 10K ohm load, with a reduced load the output can drive up to 2.0mA. An independent +5V dc power supply which provides an electrically "quiet" supply for all the analog circuitry, and a high precision low drift reference are also present on the AP board. Both the reference and SVDC supply are shared by the ADC and DAC circuitry.

2.6 Host Microcontroller Board (MCU Board)

The microcontroller board consists of an Intel 80C51FA microcontroller (MCU), address latch, EEPROM memory, SRAM memory and a watchdog timer. All the data acquisition, signal processing and display manipulation are controlled by the microcontroller. Communications to the other boards is accomplished via a serial data link comprising a set of three lines common to all the other devices (ADC, 2 EEPROMs, 2 Display Drivers). Individual select lines for each individual device, allow the MCU to communicate with one device at a time. The watchdog timer prevents the MCU from "locking up" in the event of a transient or other type of interference. The watchdog timer also provides a reset on power-up or when resuming from a brownout (low supply). The watchdog timer can be triggered manually, by entering the CT/PT set mode (See section 4.1) and holding down the select push button for approximately 1.2 seconds. In the unlikely event of a microcontroller failure, the watchdog circuit will continuously attempt to restart the processor. A positive indication of this condition is provided by having the watchdog flash both of the LED displays on the front panel. The CT/PT switch and the select pushbutton are mounted on the MCU board.

2.7 LED Display Board (LED Board)

The LED Display board consists of three 4 digit displays comprised of high efficiency red LED seven segment common cathode displays. Each 4 digit display is driven in a multiplexed fashion by an MC14499 seven segment decoder driver chip, which accepts serial data from the MCU, and decodes the data into the seven segment and digit select outputs necessary for the multiplexed display. The high current cathode drive is provided by an MC1472 driver for each pair of digits. On power up, or any other time the MCU is reset, a display test will be conducted that displays 8.8.8.8 on the top display, followed by 8.8.8.8 on the middle display, followed by 8.8.8.8 on the bottom display, followed by all dots on the alphanumeric display. The display test can be initiated by entering and then leaving the CT/PT set mode (see sec. 4.1).

For all the Watt and Var displays the "SIGN" of the quantity is indicated by the center segment of the left most digit, which will be illuminated to produce a "-" for negative quantities. Positive quantities will have no polarity indication. This restricts the display to 3 digits in the Watt and VAR display, however this is a restriction for the display only, internally the instrument still carries full precision. The Phase A Amperes (XTWIE1A) or Phase B Volts (XTWIE2A) display is a full 4 digit display.

3.0 INSTALLATION

WARNING - INSTALLATION AND MAINTENANCE SHOULD ONLY BE PERFORMED BY PROPERLY TRAINED OR QUALIFIED PERSONNEL.

3.1 Initial Inspection

Bitronics' instruments are carefully checked and "burned in" at the factory before shipment. Damages can occur, however, so please check the instrument for shipping damage as it is unpacked. Notify Bitronics immediately if any damage has occurred, and save any damaged shipping containers.

3.2 Power Requirements

MULTIFUNCTION meters are normally configured for 115V ac, 60Hz power. 230V ac, 50/60 Hz and Universal (AC/DC) are available when requested at the time of order. Power is connected to the two labeled terminals at the rear of the case as shown in Figure 4 found on Appendix page A2. Both terminals are electrically isolated from the meter case and from the electronic circuitry. Variations of the ac supply voltage of +/- 20% will not affect the performance of the instrument. The power supply and regulators provide constant dc power to the modules independent of variations in ac supply voltage over this range. If the supply voltage drops below the point at which the regulators can function properly, the watchdog timer will cause the displays to flash as described previously.

3.3 Overcurrent Protection

A UL listed 1.5 Ampere non-time delay (M) fuse is to be series connected in the ungrounded (hot) side of mains input as part of installation of this product.

3.4 Mains Disconnect

Equipment shall be provided with a Mains Disconnect, that can be actuated by the operator and simultaneously open both sides of the mains input line. The Disconnect shall be UL Recognized and acceptable for the application.

3.5 Instrument Mounting

The instrument may be mounted into a standard 4" panel opening as shown in Figure 2. Adapter plates are available for larger panel openings. Figure 3 shows the overall dimensions of the MULTIFUNCTION Meter. WARNING - DO NOT overtighten the nuts on the mounting studs, HAND tighten with a standard nut driver, 12 inch-pounds is recommended, MAXIMUM torque is 15 inch-pounds.

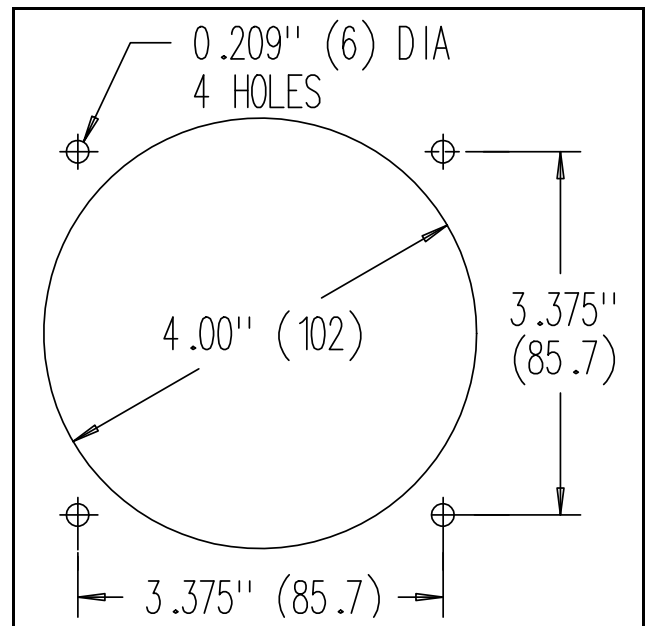

Figure 2 - Mounting Dimensions

3.6 Surge Protection

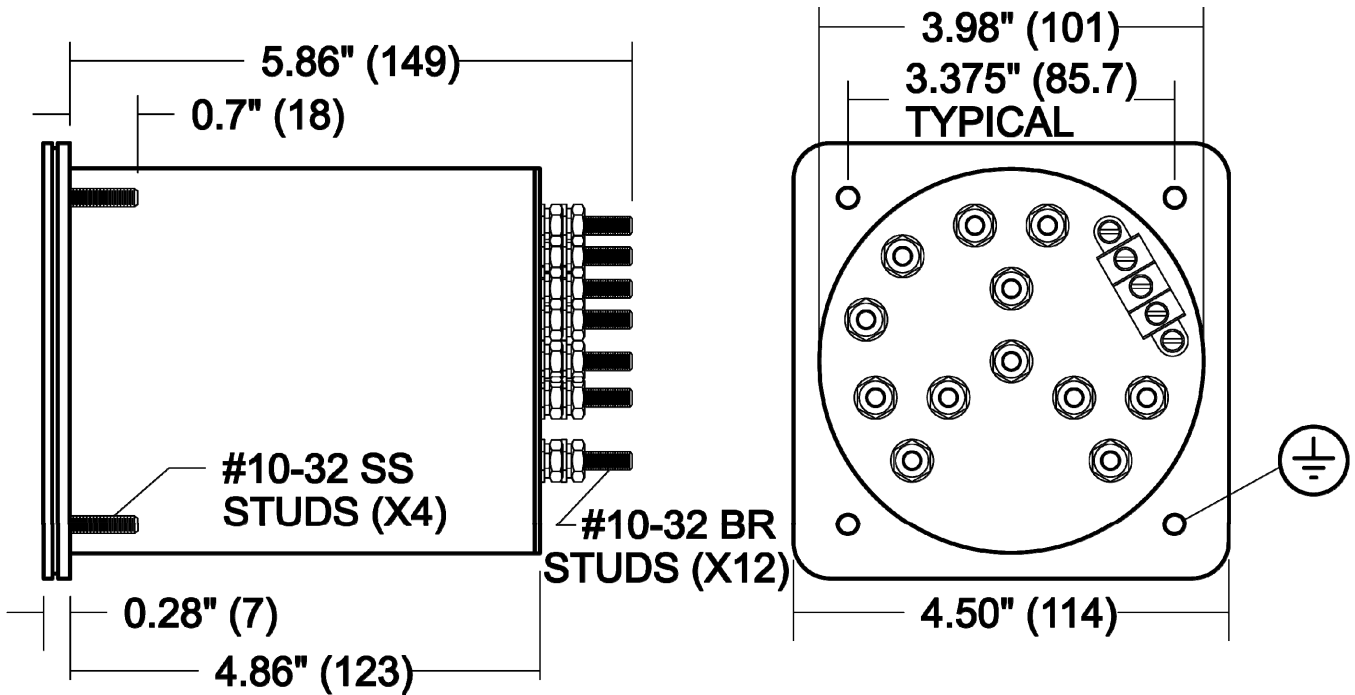

Figure 3 – Outside Dimensions

It is recommended that a metal oxide varistor (MOV) be placed across the power supply input to protect the meter in the event of high voltage surges or lightning strikes. MULTIFUNCTION Meters are shipped with a transient suppression network already attached as a standard design. An MOV provides an added measure of protection against heavy switching transients occasionally experienced in the field. The MOV is designed to clamp applied power voltages above 270V ac RMS. A single MOV protects the meter Line to Line, and two high voltage capacitors are provided to protect each Line to Ground. To avoid damaging the MOV protector, maintain continuously applied power voltages within the ratings of the instrument. The GREEN lead of the MOV assembly should be connected to a good earth ground. In most instances, this is usually accomplished by connecting the GREEN lead to the panel via the indicated front mounting stud. This mounting stud is a safety ground for the instrument, and should be connected to a protective earth circuit (refer to Figure 3). Although the Line to Ground capacitors are 3kV and UL rated, users of DC power may not want the transient protection connected from the DC supply to earth ground. In this case the GREEN lead of the MOV assembly can be clipped at the board, or the GREEN lead may be connected to either of the meter power studs. Mounting of the MOV board external to the instrument allows easy access so that the MOV and Caps may be readily inspected for damage. If the unit is to be powered from a PT, it is recommended that one side of the PT be grounded at the instrument following ANSI/IEEE C57.13.3-1983. The MOV board voltage rating is indicated on the MOV board, and must match the voltage supply rating of the instrument.

4.0 FIELD ADJUSTMENTS

The Bitronics MULTIFUNCTION Meters have been factory calibrated to display 000 +/- one digit for zero signal input. PT and CT values are set to customer values if specified, or to 5:5 CT and 1:1 PT otherwise.

4.1 Rescaling

One of the most powerful features of the MULTIFUNCTION Meters is the extreme ease of rescaling the instrument on the bench or in the field. No calibrator is needed. Even though the units are factory scaled to customer CT/PT ratios, these ratios may be changed in the field as transformers are "tapped down". Rescaling should also be checked anytime the meter is altered by the replacing of either the Electronics Module or the EPROM firmware. Rescaling is simple and is carried out in the panel as follows:

WARNING!: Any change in PT or CT ratios will zero all demand measurements!

1. With the MULTIFUNCTION meter under power, remove the four screws holding the front panel to the meter.
2. Flip the small toggle on the left of the meter UP for CT set (DOWN for PT set). The top display will show the present CT setting, the middle display will show the instrument address and the bottom display will show the present PT setting. The Alphanumeric display will indicate which ratio is being set.
3. Index through the available CT/PT ratios by repeatedly pushing the select button. All CT ratios are assumed to have 5 amps as their secondary nominal output (1 amp if CI1 option). Therefore 10.00 on the display corresponds to a 10:5 CT for a 5amp CT, or 10:1: for a 1amp CT. PTs are represented by a ratio to 1, so 4.000 on the display would correspond to a 4:1 PT (480V ac input). Powers of ten can also be set as the decimal point moves from left to right by using the select button. A momentary push of the button will cause the display to increment to the next power of ten, or to the next ratio. Holding the push button down longer than 1.2 seconds will cause the watchdog timer to reset the MCU, indicated by the display test, followed by the version number of the instrument software, followed by the display of the current CT & PT ratios. This is not a problem, and can be used to reset the MCU, check for proper watchdog operation, check software version number, or return to the current CT & PT ratio. Be sure to observe the proper position of the decimal point. CT ratios 5.000 to 9.000 have two sets of values. The first value allows maximum resolution, but does not allow the full 2X overload range to be displayed (the serial output is still accurate). A second set of values has been shifted over one digit, and allows the full 2X overload, but sacrifices one digit of resolution (only on the display).

The table of CT ratios is listed below:

1.000, 10.00, 100.0, 1000.	
1.100, 11.00, 110.0, 1100.	
1.200, 12.00, 120.0, 1200.	
1.500, 15.00, 150.0, 1500.	
1.600, 16.00, 160.0, 1600.	
2.000, 20.00, 200.0, 2000.	
2.200, 22.00, 220.0, 2200.	
2.400, 24.00, 240.0, 2400.	
2.500, 25.00, 250.0, 2500.	
3.000, 30.00, 300.0, 3000.	
3.500, 35.00, 350.0, 3500.	
4.000, 40.00, 400.0, 4000.	
4.500, 45.00, 450.0, 4500.	
5.000, 50.00, 500.0, 5000.	
0.500, 05.00, 050.0, 0500.	Expanded 5.000 range for 2X overload
6.000, 60.00, 600.0, 6000.	
0.600, 06.00, 060.0, 0600.	Expanded 6.000 range for 2X overload
7.500, 75.00, 750.0, 7500.	
0.750, 07.50, 075.0, 0750.	Expanded 7.500 range for 2X overload
8.000, 80.00, 800.0, 8000.	
0.800, 08.00, 080.0, 0800.	Expanded 8.000 range for 2X overload
9.000, 90.00, 900.0, 9000.	
0.900, 09.00, 090.0, 0900.	Expanded 9.000 range for 2X overload

4. Return the toggle to the center position. You will see a digit check (1888 displayed) and the new CT ratio will be "locked" into the meter.

5. Repeat steps 2 through 4 with the CT/PT switch in the down position to set the PT ratio. A table of the PT ratios is listed below, and consists of two sets of values. The first set of ratios are "normal ratios" for calculating Watts and Vars (XTWIE1A & XTWIE2A) and for displaying the Phase B voltage as line-to-neutral (L-N) voltage from the L-N PT (XTWIE2A). the XTWIE2A also has a second set of ratios which include a square-root of 3 SCALE FACTOR, which allows the user to display the L-N voltage in L-L units, this second table is explained on the next page. XTWIE2A-NS0004 displays the voltage in Secondary Units, the user must still set the PT ratio, since this ratio is used to calculate primary Watts and Vars.

PT ratios for displaying L-N in L-N units:

1.000, 10.00, 100.0, 1000.
1.100, 11.00, 110.0, 1100.
1.155, 11.55, 115.5, 1155. relay ratio
1.200, 12.00, 120.0, 1200.
1.400, 14.00, 140.0, 1400.
1.500, 15.00, 150.0, 1500.
1.732, 17.32, 173.2, 1732. relay ratio
1.750, 17.50, 175.0, 1750.
1.800, 18.00, 180.0, 1800.
2.000, 20.00, 200.0, 2000.
2.309, 23.09, 230.9, 2309. relay ratio
2.400, 24.00, 240.0, 2400.
2.500, 25.00, 250.0, 2500.
2.511, 25.11, 251.1, 2511. relay ratio
3.000, 30.00, 300.0, 3000.
3.464, 34.64, 346.4, 3464. relay ratio
3.500, 35.00, 350.0, 3500.
4.000, 40.00, 400.0, 4000.
4.350, 43.50, 435.0, 4350.
4.500, 45.00, 450.0, 4500.
5.000, 50.00, 500.0, 5000.
5.774, 57.74, 577.4, 5774. relay ratio
6.000, 60.00, 600.0, 6000.
6.350, 63.50, 635.0, 6350.
6.642, 66.42, 664.2, 6642.
6.928, 69.28, 692.8, 6928. relay ratio
7.000, 70.00, 700.0, 7000.
8.000, 80.00, 800.0, 8000.
8.083, 80.83, 808.3, 8083. relay ratio

As was mentioned previously, the XTWIE2A contains a second set of ratios which include a square-root of 3 factor, which allows the user to display the L-N voltage in L-L units. WARNING: This is a scaled value only, and does not represent the true line-to-line voltage, except under ideal conditions. This fictitious ratio is only used in the calculation of the VOLTAGE DISPLAY, it does not affect the WATTS or VARs calculation, nor does it affect the value of the 0-1mA output.

Some of the relaying ratios when multiplied by a square-root of 3 result in a standard ratio (for example $6928 \times \sqrt{3} = 1200$). Additionally some normal ratios when multiplied by a square-root of 3 result in a normal relaying ratio (for example $1000 \times \sqrt{3} = 1732$). In both these instances, and others like them, the PT ratio in the table below has been reduced by 1. This has been done to give the user a clear indication that a PT ratio has been selected to display SCALED L-N volts, it does not affect the accuracy of the actual calculations.

Scaled PT ratios for displaying L-N in **SCALED** L-L units (XTWIE2A only):

1.039, 10.39, 103.9, 1039.	(6000*sqrt(3))
1.099, 10.99, 109.9, 1099.	(6350*sqrt(3))
1.150, 11.50, 115.0, 1150.	(6642*sqrt(3))
1.199, 11.99, 119.9, 1199.	(6928*sqrt(3))
1.212, 12.12, 121.2, 1212.	(7000*sqrt(3))
1.386, 13.86, 138.6, 1386.	(8000*sqrt(3))
1.399, 13.99, 139.9, 1399.	(8083 *sqrt(3))
1.731, 17.31, 173.1, 1731.	(1000*sqrt(3))
1.905, 19.05, 190.5, 1905.	(1100*sqrt(3))
1.999, 19.99, 199.9, 1999.	(1155*sqrt(3))
2.078, 20.78, 207.8, 2078.	(1200*sqrt(3))
2.425, 24.25, 242.5, 2425.	(1400*sqrt(3))
2.598, 25.98, 259.8, 2598.	(1500*sqrt(3))
2.999, 29.99, 299.9, 2999.	(1732*sqrt(3))
3.031, 30.31, 303.1, 3031	(1750*sqrt(3))
3.118, 31.18, 311.8, 3118.	(1800*sqrt(3))
3.463, 34.63, 346.3, 3463.	(2000*sqrt(3))
3.999, 39.99, 399.9, 3999.	(2309*sqrt(3))
4.157, 41.57, 415.7, 4157.	(2400*sqrt(3))
4.330, 43.30, 433.0, 4330.	(2500*sqrt(3))
4.349, 43.49, 434.9, 4349.	(2511*sqrt(3))
5.196, 51.96, 519.6, 5196.	(3000*sqrt(3))
5.999, 59.99, 599.9, 5999.	(3464*sqrt(3))
6.062, 60.62, 606.2, 6062.	(3500*sqrt(3))
6.927, 69.27, 692.7, 6927.	(4000*sqrt(3))
7.534, 75.34, 753.4, 7534.	(4350*sqrt(3))
7.794, 77.94, 779.4, 7794.	(4500*sqrt(3))
8.660, 86.60, 866.0, 8660.	(5000*sqrt(3))
9.999, 99.99, 999.9, 9999.	(5774*sqrt(3))

6. Replace gasket, the front cover, and the four cover screws. Done!

The position of the decimal point for the WATTS and/or VARs display is automatically calculated by the microcontroller; this provides up to three decades of range. With the standard Megawatt/Megavar faceplate, 9.99 to 999 megawatts can be accommodated. For measurements outside this range, alternate faceplates are available with units of Watts/Vars, kilowatts/kilovars, megawatts x1000/megavars x1000.

4.2 Calibration

Routine recalibration is not recommended, or required. However some drift or aging may cause slight errors after years of use. Additionally, users may wish to have a MULTIFUNCTION Meter "agree" with other instruments. To accommodate both these instances, a "Master Gain" trimpot has been provided. This trim adjusts the overall scale factor by +/- 10%, and is accessed in the following manner:

1. Remove the four cover screws. Remove the front cover and gasket.
2. Remove calibration seal located in upper right-hand corner of the display board, this will allow access to the trimpot located on the Analog Processing board.
3. Insert a small screwdriver through the opening, and into the slot of the screw on the trimpot.
4. With the meter powered, AND WITH A PRECISION KNOWN INPUT, rotate the screw clockwise to increase the measurement, or counter-clockwise to decrease the indicated measurement. NOTE: Because these WATT/VAR meters are a full 3 elements, the instrument can be calibrated with a single phase source, all current inputs should be connected in series, and all potential inputs should be connected in parallel.
5. Remove the screwdriver, and replace the calibration seal.
6. Replace gasket, the front cover, and the four cover screws.

The serial communications data output will track the display, so recalibrating the display automatically recalibrates the output. The output data cannot be calibrated independently.

4.3 Self Test Modes

The MULTIFUNCTION instruments are based on a microcontroller, and therefore can capitalize on the power of such a device. One of the areas where the power of the microcontroller enhances the overall performance of the instrument is in the area of "self-testing". The MULTIFUNCTION meters have several self tests built in to assure that the instrument is performing accurately. Table I on the following page lists possible faults that would be detected by the self tests, how the fault is indicated, the effects of the fault and any necessary corrective actions.

4.5 Cleaning

Cleaning the exterior of the instrument shall be limited to the wiping of the instrument using a soft damp cloth applicator with cleaning agents that are not alcohol based, and are nonflammable, nonexplosive.

TABLE I - SELF TEST RESULT SUMMARY FOR 3-PHASE MULTIFUNCTION METERS

Fault	Fault Indication	Effects of Fault	Corrective Action
1. Display Overflow	Display flashes 9999	Measured quantity is too large to be displayed. Communication option output may still be accurate, if overload does not exceed meter input ratings.	Correct fault external to instrument.
2. CT/PT ratio checksum error	Top display alternately displays 4 dashes (----) and fault code 1 (---1).	Scaling of the display cannot occur due to the loss of the CT and/or PT ratios. The communication option outputs are still functional and accurate except the CT & PT ratio.	Attempt to reset the CT&PT ratios. If Fault continues, replace Power Supply Board and recalibrate the instrument, or replace the Base Module.
3. CT/PT board calibration checksum error	Top display alternately displays reading and fault code 2 (---2).	Calibration constants for the CT/PT Board are in error. The display and the communication option output are reduced in accuracy to approximately +/-3%.	Replace Power Supply Board and recalibrate the instrument, or replace the Base Module.
4. Analog board calibration checksum error	Top display alternately displays reading and fault code 3 (---3).	Calibration constants for the Analog Processing Board are in error. The display and the communication option output are reduced in accuracy to approximately +/-3%.	Replace Analog Processing Board or the Electronics Module.
5. Watchdog timer timeout	All displays alternately display readings and blanks.	The watchdog timer is attempting to reset the microcontroller due to low supply voltage, or a fault in the microcontroller. Displayed values are inaccurate and communication option will cease transmitting.	Check input supply voltage to verify it is within specifications. If supply is OK, replace Host Microcontroller Board, or replace Electronics Module.

TABLE I - SELF TEST RESULT SUMMARY FOR 3-PHASE MULTIFUNCTION METERS (cont'd)

Fault	Fault Indication	Effects of Fault	Corrective Action
6. Input Over-Range	Top display alternately displays reading and fault code 4 (---4).	Peak input quantity exceeds the range of the instrument. Both display and communication option output accuracy reduced by an amount depending upon the degree of over-range.	Verify input signals are within range. If within range, replace analog processing board or the electronics module.
7. Program memory error	Top display indicates fault code 5 (---5) then executes power-up display sequence.	The microcontroller has detected a fault in program memory and is attempting to restart itself. Communication option will cease transmitting as long as the fault exists.	Replace Host Microcontroller board or electronics module.
8. Analog-to-Digital converter (ADC) self-test error	Top display alternately displays 4 dashes (----) and fault code 6 (---6), other displays show 4 dashes (----).	Instrument cannot read any signals. Data returned by communications option will be corrupted.	Replace analog processing board or the electronics module.
9. XRAM failure	Top display alternately displays reading and fault code 7 (---7).	Displayed quantities will no longer be averaged, accuracy may degrade to 0.5%. Data returned by communications option may be corrupted.	Replace Host Microcontroller Board or Electronics Module.

4.5 Electronics Module Removal

The Electronics Module consists of the Analog Processing Board (AP), the Host Microcontroller Board (MCU), and LED Display Board (LED). In the unlikely event of a board failure, it may be necessary to remove the Electronics Module from the instrument. Bitronics has designed the Multifunction meters in a modular fashion to facilitate this repair in the field, by allowing the module to be removed with the meter powered and in the panel. The procedure is as follows:

1. Remove the four screws holding the front panel to the meter. Remove the faceplate and gasket.
2. Remove the two roundhead screws located at 3 and 9 o'clock (labeled "REMOVE").
3. A wire bail is located at the top of the module, pull gently on the bail, and the Electronics Module will pull out (a slight rocking motion may be required). **CAUTION** - when the Electronics Module is removed with the instrument powered, instrument power (115V ac or 230V ac) is present on the circuit boards that remain in the Base Module. DO NOT touch or insert metallic objects into the Base Module while the instrument is powered.
4. To reinsert the Electronics Module, first make sure the Modbus Plus flex circuit and connector are carefully dressed to the side, so that they are not damaged when the module is inserted. Next align the two 0.25" round guide rails with the two holes in the bottom board of the Electronics Module. Gently push the Electronics Module in until the module is fully seated (DO NOT FORCE!!).
5. Replace the two roundhead screws located at 3 and 9 o'clock. Push the wire bail back into the meter.
6. Check CT and PT ratios and reset if necessary (See section 4.1 Rescaling).
7. Replace gasket, the front cover, and the four cover screws.

5.0 QUESTIONS AND ANSWERS

1. What happens if the applied CT signal exceeds 5A?

The MULTIFUNCTION meters are accurate to twice the normal full scale limit (to 10A). The unit will operate at 100% overload without damage, however on some CT/PT settings the display will over-range, causing the display to flash with 1999. The 0-1 milliamp output is still accurate even if the display overranges, provided the load resistance is low enough to support the increased current.

2. Can the Electronics Module be removed under power?

Yes. Neither input signals nor power need be disconnected to remove or rescale the Electronics Module. Removing the module DOES NOT open the CTs or PTs.

3. Is routine calibration necessary?

No, nor is it recommended. More problems are caused by improper calibration than by faulty meters. A calibration check every few years in the field is good assurance, however. If there is a question about the meter, exchanging a module may help verify performance.

4. HI and LO are marked on the inputs. Does polarity matter?

Yes! Correct wiring with proper polarity is essential for proper operation.

5. Can I put MULTIFUNCTION meters in an outdoor cabinet?

Yes. Many Bitronics meters are installed that way. The temperature range of -20C to 70C covers most applications. The case is gasketed, but not waterproof, so it must be placed within an enclosure that provides ingress protection acceptable for the application in accordance with IEC 529, UL 840 or the equivalent NEMA Standard.

6. How long will MULTIFUNCTION meters save the CT/PT ratio without power?

The data is saved in a nonvolatile memory (EEPROM) which does not require battery backup. Retention is estimated by the manufacturer to exceed 10 years without refreshing. In any event, long enough to exceed an outage, or for any inactive storage period.

6. I have a low voltage circuit, can I operate MULTIFUNCTION meters without the use of CTs and PTs?

Although the MULTIFUNCTION meter has been optimized for use with CTs and PTs, it can be connected directly to a load provided that the voltages and currents do not exceed the rating of the device. The internal CT should be set to 5 (5:5) and the internal PT should be set to 1 (120: 120).

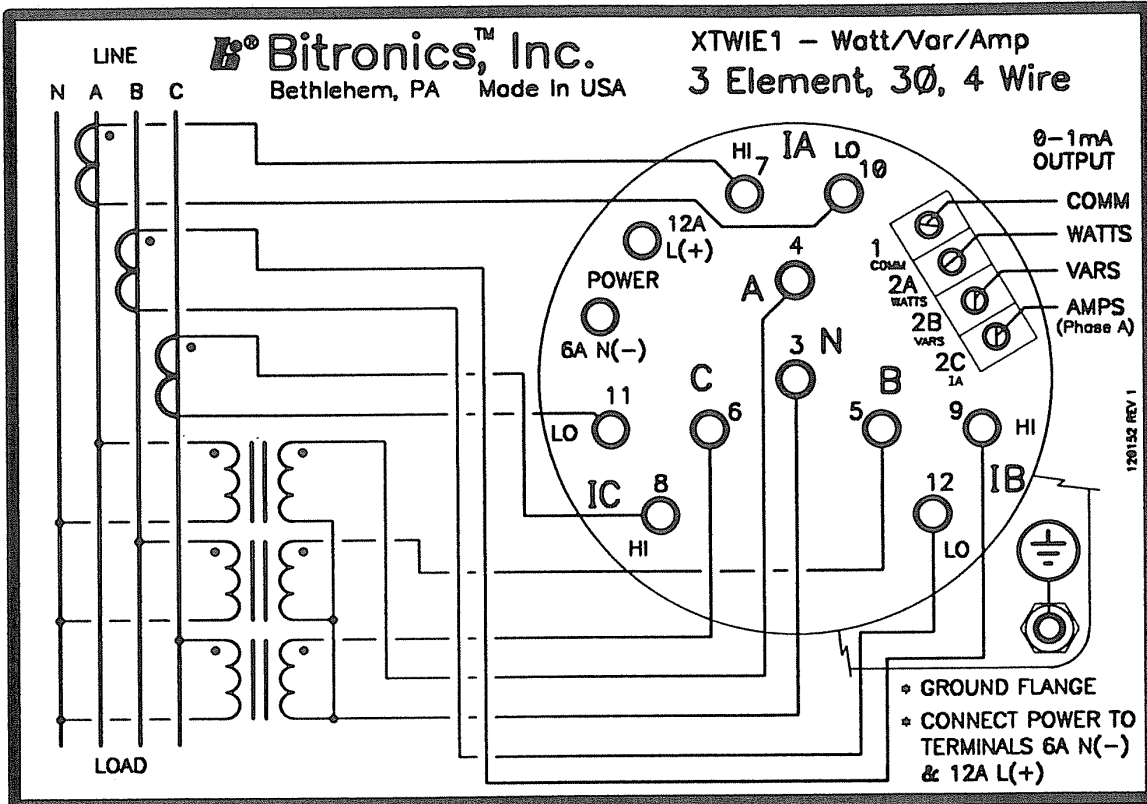

Figure 4 - Typical connection diagram for XTWIE1A

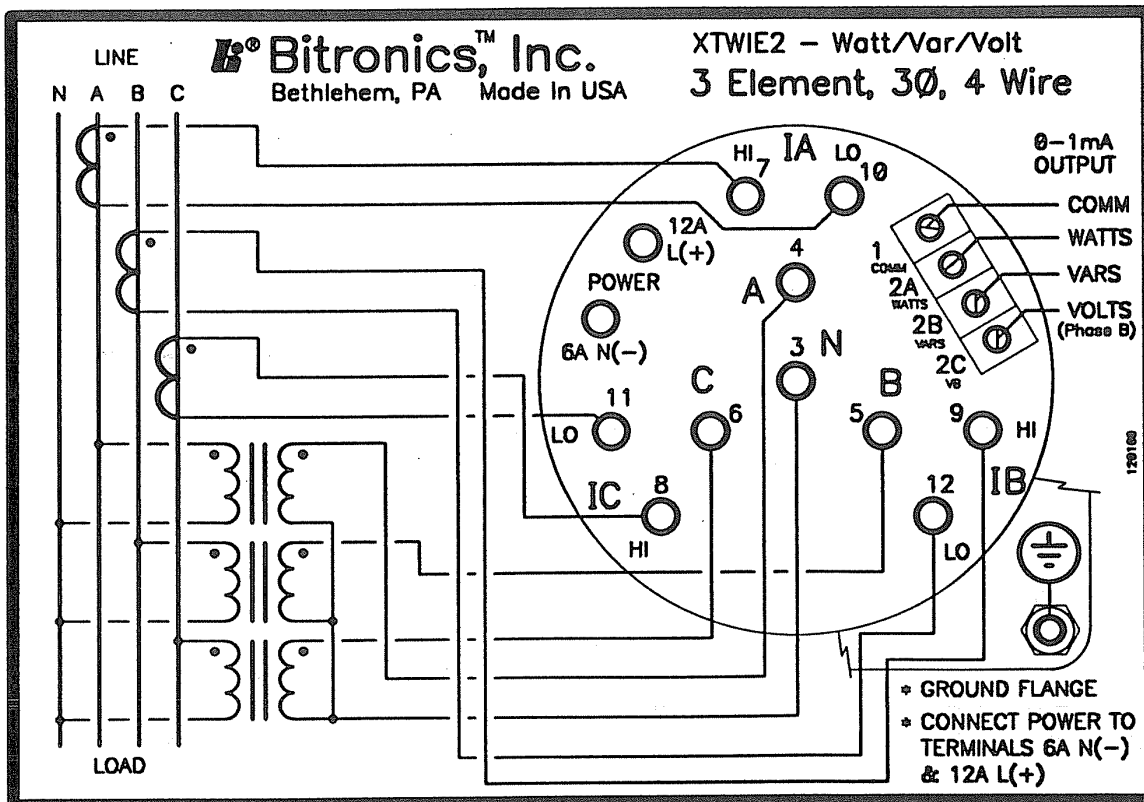

Figure 5 - Typical connection diagram for XTWIE2A and XTWIE2A-NS0004

Revision	Date	Changes	By
A	01/30/2009	Update Bitronics Name, Logo	E. Demicco
B	10/22/2009	Updated logos and cover page	MarCom
C			

