



August 7, 2009
ML0031 Document Revision B
© 2009 by Bitronics, LLC

(Includes 0-1mA Transducer Outputs)
No. QTWIE3 WATT/VAR METER
No. WTWIE5 WATTMETER
No. RTWIE5 VARMETER

TABLE OF CONTENTS

TABLE OF CONTENTS	i
CERTIFICATION	ii
COPYRIGHT	ii
INSTALLATION AND MAINTENANCE	ii
WARRANTY AND ASSISTANCE	ii
1.0 DESCRIPTION	1
1.1 Introduction	1
1.2 Features	1
1.3 Specifications	2
2.0 PRINCIPLES OF OPERATIONS	3
2.1 Modular Construction	3
2.2 Input Signal Connections	3
2.3 Current and Potential Transformer Board (CT/PT Board)	4
2.4 Power Supply Board (PS Board)	4
2.5 Analog Processing Board (AP Board)	5
2.6 Microcontroller Board (MCU Board)	6
2.7 LED Display Board (LED Board)	6
3.0 INSTALLATION	7
3.1 Initial Inspection	7
3.2 Power Requirements	7
3.3 Overcurrent Protection	7
3.4 Mains Disconnect	7
3.5 Instrument Mounting	7
3.6 Surge Protection	8
4.0 FIELD ADJUSTMENTS	9
4.1 Rescaling	9
4.2 Calibration	11
4.3 Self Test Modes	11
4.4 Cleaning	11
4.5 Electronics Module Removal	15
5.0 QUESTIONS AND ANSWERS	14
6.0 WIRING DIAGRAMS	15

CERTIFICATION

Bitronics, LLC certifies that the calibration of its products are based on measurements using equipment whose calibration is traceable to the United States National Institute of Standards Technology (NIST).

COPYRIGHT

This Manual is copyrighted and all rights are reserved. The distribution and sale of this manual are intended for the use of the original purchaser or his agents. This document may not, in whole or part, be copied, photocopied, reproduced, translated or reduced to any electronic medium or machine-readable form without prior consent of Bitronics LLC, except for use by the original purchaser.

INSTALLATION AND MAINTENANCE

Bitronics' products are designed for ease of installation and maintenance. As with any product of this nature, however, such installation and maintenance can present electrical hazards and should only be performed by properly trained and qualified personnel. If the equipment is used in a manner not specified by Bitronics, the protection provided by the equipment may be impaired.

WARRANTY AND ASSISTANCE

Products manufactured by Bitronics LLC are warranted against defects in materials and workmanship for a period of thirty-six (36) months from the date of their original shipment from the factory. Products repaired at the factory are likewise warranted for eighteen (18) months from the date the repaired product is shipped, or for the remainder of the product's original Warranty, whichever is greater. Obligation under this warranty is limited to repairing or replacing, at Bitronics' factory, any part or parts which Bitronics' examination shows to be defective. Warranties only apply to products subject to normal use and service. There are no warranties, obligations, liabilities for consequential damages, or other liabilities on the part of Bitronics except this Warranty covering the repair of defective materials. The warranties of merchantability and fitness for a particular purpose are expressly excluded.

For assistance, contact Bitronics LLC at:

Telephone: 610.997.5100
Fax: 610.997.5450
Email: bitronics@novatechps.com
Website: www.novatechweb.com/bitronics

Shipping:

261 Brodhead Road
Bethlehem, PA 18017-8698
USA

1.0 DESCRIPTION

1.1 Introduction

Real and reactive power are essential quantities which must be measured accurately in order to optimize the control and delivery of electric power. State of the art technology makes it possible to measure these functions very accurately, over a wide range of input signals. The Bitronics Three Phase WATT/VAR Meters are rugged electronic instruments designed for utility and industrial applications requiring reliable, precise measurements of three-phase real power (WATTS) and/or reactive power (VARs). The family consists of WATTMETERS, VARMETERS, and WATT/VAR METERS. True RMS measurements are standard, and include harmonics beyond the 7th harmonic in both the current and voltage inputs, resulting in accurate measurements, even with distorted waveforms. The use of "State-of the Art" microprocessor technology assures digital accuracy and repeatability across the entire range of input signal levels. WATT/VAR meters are modular in design, with push-button rescaling to display primary values when using any standard current and voltage transformer. Rescaling can be done in the field, in a matter of minutes, without removing the instrument from the panel or the need for any calibration equipment. Physical dimensions are the standard 4" round case with an overall length of 6.5 inches.

1.2 Features

- * Simultaneously displays three-phase, true WATTS and/or VARs.
- * Push-button rescaling in the field accommodates all ANSI CT and PT ratios. Displays primary or secondary values. (Non-standard ratios available, consult factory.)
- * Field-changeable modular design for easy maintenance.
- * Single push button selects CT/PT setting, and also resets the microprocessor.
- * Non-volatile memory backup of CT/PT settings. No batteries are needed.
- * Rugged metal housing fits standard 4" round cutout.
- * True RMS measurements are standard.
- * 3 1/2 digit high efficiency LEDs for easy reading.
- * Standard 0 to +/-1mA DC current outputs proportional to WATTS and/or VARs, for connecting to SCADA or other equipment. (Two outputs on QTWIE3 only)
- * Watchdog timer maximizes system reliability.

1.3 Specifications

Input Signals

Amperes: 0 to 5A ac nominal, three phase, with continuous overload to 10A ac, 400A ac for 2 seconds. 1500Vac isolation, minimum.

Volts: 0 to 150V ac nominal, three phase. 1500Vac isolation, minimum.

Signal Burden

Amperes: 4 mV ac at 5A ac input (0.02 VA).

Volts: <1 mA ac at 120V ac input (0.1 VA).

Display: 0000 to +/-1999 with decimal determined by CT/PT ratio.

Scaling: User selectable using internal CT/PT tables.

Accuracy: 0.25% Class (ANSI Std 460-1988).

Signal Frequency: 50Hz to 400Hz (Including Harmonics).

Current Output: 0 to +/- 1mA into 10K ohms or less; 0.4% ripple p-p or less. Calibrated at 1500W at meter input. Overload to +/- 2mA into 5K ohms or less.

Power Requirements: 115 Vac +/- 20%, 6 VA (230 Vac or Universal AC/DC optional)

Fuse: 1.5 Ampere, non-time delay (M) fuse, UL listed located in the ungrounded (hot) side of the line, external to meter.

Operating Temperature: -30C to 70C. Humidity: 0-95% non-condensing

Installation Category: IC III

Weight: 2.5 pounds (1.14 kilograms)

2.0 PRINCIPLES OF OPERATION

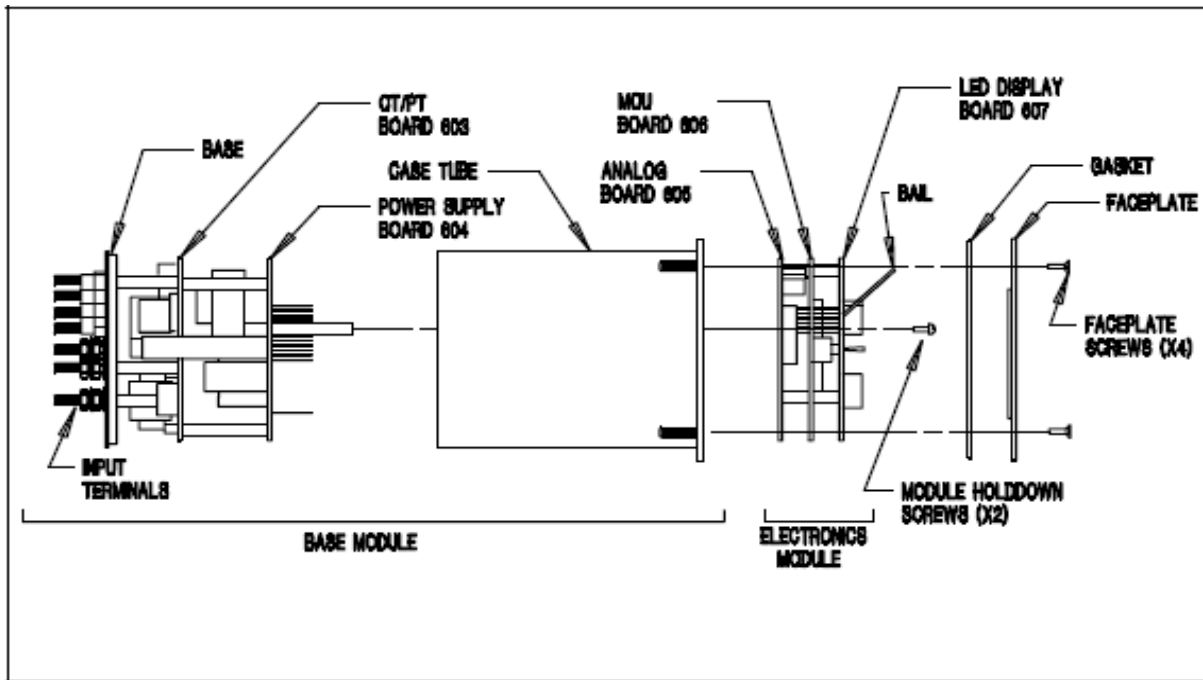

Figure 1 - WATT/VAR Meter Exploded View (QWIE1 Shown)

2.1 Modular Construction

The Bitronics WATT/VAR Meters are composed of two major modules, as shown in the exploded view of the meter (Figure 1). The BASE MODULE consists of the case tube, the back panel, the Current Transformer & Potential Transformer Board and the Power Supply Board. The Base Module contains primarily passive components (transformers, connectors, etc.) and cannot be serviced without removal from the panel. The ELECTRONICS MODULE consists of the Analog Processing Board, Microcontroller Board and the LED Display Board. Ninety percent of the active electronics (Integrated Circuits, diodes, etc.) are contained within the three boards comprising the Electronics Module. This module can easily be removed for maintenance without the need to remove the meter from the panel, or to remove the meter from service (see section 4.4). Detailed descriptions of each of the boards can be found in the following sections.

2.2 Input Signal Connections

The WATT/VAR Meters have six independent signal inputs; one current and one voltage for each phase being measured. Current and voltage signals are connected directly to #10-32 brass studs on the rear panel of the instrument. **WARNING - DO NOT** overtighten the nuts on the input connections, **HAND** tighten with a standard nutdriver, 12 inch-pounds is recommended, **MAXIMUM** torque is 15 inch-pounds. The instrument can be connected directly to current transformer (CT) or potential transformer (PT) circuits. The impedance at the WATT/VAR terminals is nearly a short circuit (2 milliohms) for ammeters and high impedance (> 100 K-ohms) for voltmeters. These ideal impedances provide low burden loads for the CT or PT circuits supplying the signals. The polarity of the applied signals is

important to the function of the instrument, and the signal terminals are labeled LO or HI to aid in wiring the units into substation or control panels. A wiring diagram is also provided in the form of a decal on the side of the meter. Grounding of PT & CT signals per ANSI/IEEE C57.13.3-1983 is recommended.

Power is applied to two #10-32 brass studs, also located on the rear cover of the instrument. **WARNING - DO NOT** overtighten the nuts on the input connections, **HAND** tighten with a standard nutdriver, 12 inch-pounds is recommended, **MAXIMUM** torque is 15 inch-pounds. Because of the solid state design, the total load required to operate the unit is only six WATTS. It is therefore possible to power the WATT/VAR Meter with AC station power or an auxiliary PT, provided the voltage remains above 90 volts. Units are normally shipped configured for 115Vac, however they may be special ordered with a 230Vac or Universal (AC/DC) supply.

2.3 Current and Potential Transformer Board (CT/PT Board)

The current and potential transformer (CT/PT) board contains secondary transformers which provide electrical isolation for each of the signal input channels. Current from the current terminals flows through a silver-soldered shunt of negligible resistance to assure that the user's external CT circuit can never open-circuit, even under extreme fault conditions. Potential voltages are carried through 10-32 studs directly to the CT/PT board to guarantee reliable connections to the high-impedance secondary transformer circuits. The use of transformer isolation on all input leads provides excellent isolation (1500Vac) between the inputs and any output.

2.4 Power Supply Board (PS Board)

The power supply circuit is a conservative, conventional design. Low drop rectifiers and a low drop-out solid state regulator minimize internal power dissipation. Filter capacitors are operated at a fraction of their voltage and temperature ratings, and should provide years of trouble-free service under extreme environmental conditions.

Bitronics WATT/VAR instruments provide for complete interchangeability among signal processing and display modules. Compensation for normal variations in input circuits is achieved by storing calibration constants in a non-volatile memory (EEPROM) which resides on the PS board. These constants are factory-programmed to provide identical signal gain (attenuation) in each of the six isolated signal input paths. The CT and PT settings for scaling the display to the user's CTs and PTs are also stored in this EEPROM. Checksums are incorporated into the EEPROM which are read periodically by the microcontroller to check the integrity of the calibration constants and the CT and PT setting (See section 4.3).

2.5 Analog Processing Board (AP Board)

The first function of Analog Processing board is to sample and digitize the low level AC signals provided by the CT/PT board, and to provide a digital number to the microcontroller (MCU) for further processing. Signal processing begins with the low level AC signal supplied from the CT/PT board which is about one volt ac RMS for a full scale input signal. Pure sine wave inputs or complex, distorted, periodic waveforms are handled equally well - a major advantage when computing WATTS and VARs for unknown current and voltage waveforms. This design frees the user from concern about errors which will otherwise occur during the measurement of distorted waveforms with non-true RMS instruments. Voltage of a given phase is sampled first, followed by the current of the same phase. Phases A, B and C are sampled in succession, providing the MCU with instantaneous measurements of all voltage and current inputs. Samples are accumulated for 0.5 seconds, at which time the MCU calculates the WATTS and VARs for each phase. The VARS quantity for each phase is derived from a power triangle calculation where the WATTS and VAs are known. This technique provides a "true" measure of VARs even with distorted waveforms. Zero offset is also adjusted for each signal channel every 0.5 seconds by the MCU. These per phase quantities are then summed to form the total three phase WATTS and VARS. Calibration constants stored in both the Power Supply EEPROM and the EEPROM located on this board provide drift-free calibration, and complete interchangeability of Analog Processing boards. Checksums are incorporated into both EEPROMs which are read periodically by the microcontroller to check the integrity of the calibration constants and the CT and PT setting (See section 4.3). A "Master Gain" trimpot is also located on the AP board to provide the user with fine tuning capability if it is necessary to match other devices on the power system. Once the total WATTS and VARS have been calculated, the MCU scales the values by the external PT and CT ratios which have been selected by the user, and displays the values.

A second function of the AP board is to provide the 0 to +/-1 milliamp transducer output(s). This is accomplished with 12-bit digital to analog converters (DAC), one for each output channel. Constants stored in the EEPROM on the analog board are read by the MCU and used to compensate for gain and offset of each output channel. This technique provides stable calibrations for the output(s). Additional circuitry converts the output of each DAC to the 0 to +/-1 milliamp current. This additional circuitry is powered from a +15volt and a -15volt supply also located on the AP module. The outputs have a +/- 10volt compliance, and can drive a +/-1.0mA into a 10k ohm load, with a reduced load the output can drive up to +/-2.0mA. An independent +5 volt power supply which provides an electrically "quiet" supply for all the analog circuitry, and a high precision low drift reference are also present on the AP board. Both the reference and 5volt supply are shared by the ADC and DAC circuitry.

2.6 Microcontroller Board (MCU Board)

The microcontroller board consists of an Intel 80C51FA microcontroller (MCU), address latch, EPROM memory and a watchdog timer. All the data acquisition, signal processing and display manipulation are controlled by the microcontroller. Communications to the other boards is accomplished via a serial data link comprising a set of three lines common to all the other devices (ADC, 2 DACs, 2 EEPROMs, 2 Display Drivers). Individual select lines for each individual device, allow the MCU to communicate with one device at a time.

The watchdog timer prevents the MCU from "locking up" in the event of a transient or other type of interference. The watchdog timer also provides a reset on power-up or when resuming from a brownout (low supply). The watchdog timer can be triggered manually, by entering the CT/PT set mode (See section 4.1) and holding down the select push button for approximately 1.2 seconds. In the unlikely event of a microcontroller failure, the watchdog circuit will continuously attempt to restart the processor. A positive indication of this condition is provided by having the watchdog flash both of the LED displays on the front panel. The CT/PT switch and the select pushbutton are also mounted on the MCU board.

2.7 LED Display Board (LED Board)

The LED Display board consists of two 3 1/2 digit displays (one in the case of the WTWIE5 or RTWIE5), comprised of high efficiency red LED seven segment common cathode displays. Each 3 1/2 digit display is driven in a multiplexed fashion by an MC14499 seven segment decoder driver chip, which accept serial data from the MCU, and decodes the data into the seven segment and digit select outputs necessary for the multiplexed display. The high current cathode drive is provided by an MC1472 driver for each pair of digits. On power up or any other time the MCU is reset, a display test will be conducted that displays +1.8.8.8 on the top display, followed by +1.8.8.8 on the bottom display (QTWIE3 only). The display test can be initiated by entering and then leaving the CT/PT set mode (see section 4.1).

3.0 INSTALLATION



WARNING - INSTALLATION AND MAINTENANCE SHOULD ONLY BE PERFORMED BY PROPERLY TRAINED OR QUALIFIED PERSONNEL.

3.1 Initial Inspection

Bitronics' instruments are carefully checked and "burned in" at the factory before shipment. Damages can occur, however, so please check the instrument for shipping damage as it is unpacked. Notify Bitronics immediately if any damage has occurred, and save any damaged shipping containers.

3.2 Power Requirements

WATT/VAR meters are normally configured for 115V ac, 60Hz power. 230V ac, 50/60Hz and Universal (AC/DC) are available when requested at the time of order. Power is connected to the two labeled terminals at the rear of the case as shown in Figure 4. Both terminals are electrically isolated from the meter case and from the electronic circuitry. Variations of the ac supply voltage of +/- 20% will not affect the performance of the instrument. The power supply and regulators provide constant dc power to the modules independent of variations in ac supply voltage over this range. If the supply voltage drops below the point at which the regulators can function properly, the watchdog timer will cause the displays to flash as described previously.

3.3 Overcurrent Protection

A UL listed 1.5 Ampere non-time delay (M) fuse is to be series connected in the ungrounded (hot) side of mains input as part of installation of this product.

3.4 Mains Disconnect

Equipment shall be provided with a Mains Disconnect, that can be actuated by the operator and simultaneously open both sides of the mains input line. The Disconnect shall be UL Recognized and acceptable for the application.

3.5 Instrument Mounting

The instrument may be mounted into a standard 4" panel opening as shown in Figure 2. Adapter plates are available for larger panel openings. Figure 3 shows the overall dimensions of the WATT/VAR meter. WARNING - DO NOT overtighten the nuts on the mounting studs, HAND tighten with a standard nut driver, 12 inch-pounds is recommended, MAXIMUM torque is 15 inch-pounds.

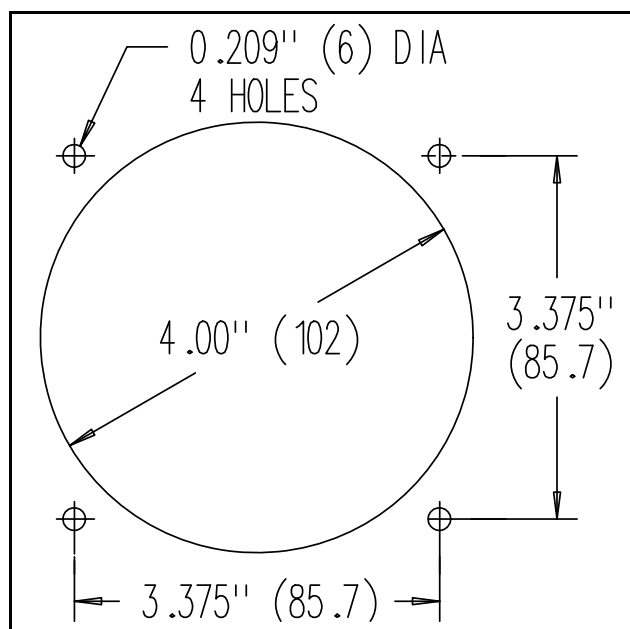

Figure 2 - Mounting Dimensions

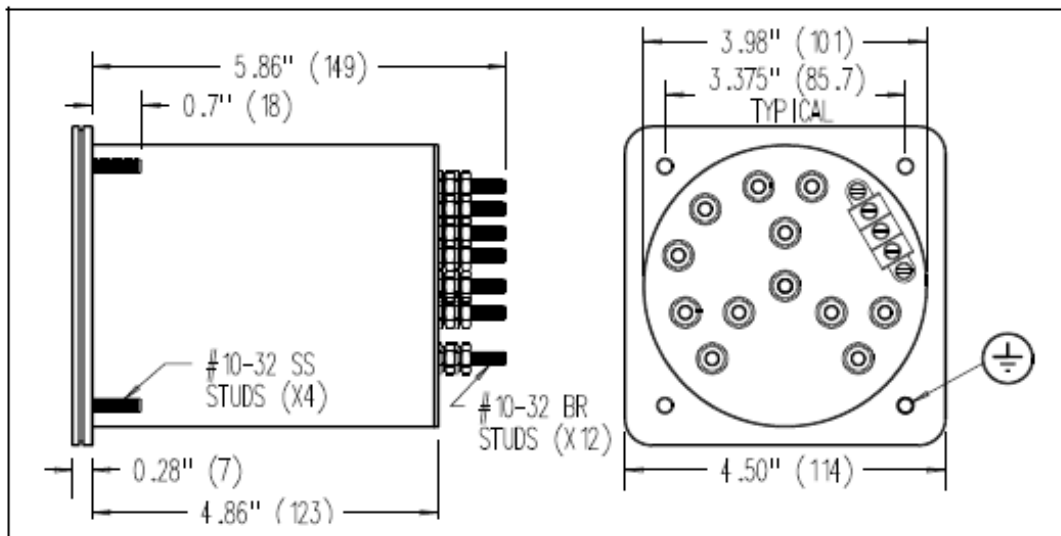

Figure 3 - Outside Dimensions

3.6 Surge Protection

It is recommended that a metal oxide varistor (MOV) be placed across the power supply inputs to protect the meter in the event of high voltage surges or lightning strikes. WATT/VAR meters are shipped with a transient suppression network already attached as a standard design. The MOV provides an added measure of protection against heavy switching transients occasionally experienced in the field. The MOV is designed to clamp applied power voltages above 170V ac RMS (270 V ac RMS for 220V instruments). A single MOV protects the meter Line to Line, and two high voltage capacitors are provided to protect each Line to Ground. To avoid damaging the MOV protectors, maintain continuously applied power voltages within the ratings of the instrument. The GREEN lead of the MOV assembly should be connected to a good earth ground. In most instances, this is usually accomplished by connecting the GREEN lead to the indicated front mounting stud. This mounting stud is a safety ground for the instrument, and should be connected to a protective earth circuit (refer to Figure 3). Although the Line to Ground capacitors are 3kV and UL rated, users of DC powered instruments may wish to eliminate the Line to Ground protection, these users may do so by clipping the GREEN lead at the MOV board and discarding the GREEN lead. Mounting of the MOVs external to the instrument allows easy access so that the MOVs may be readily inspected for damage. If the unit is to be powered from a PT, it is recommended that one side of the PT be grounded at the instrument following ANSI/IEEE C57.13.3-1983. The MOV board voltage rating is indicated on the MOV board, and must match the voltage supply rating of the instrument.

4.0 FIELD ADJUSTMENTS

The Bitronics WATT/VAR meters have been factory calibrated to display 000 +/- one digit for zero signal input. PT and CT values are set to customer values if specified, or to 5:5 CT and 1:1 PT otherwise.

4.1 Rescaling

One of the most powerful features of the WATT/VAR meters is the extreme ease of rescaling the instrument on the bench or in the field. No calibrator is needed. Even though the units are factory scaled to customer CT/PT ratios, these ratios may be changed in the field as transformers are "tapped down". Rescaling should also be checked anytime the meter is altered by the replacing of either the Electronics Module or the EPROM firmware. Rescaling is simple and is carried out in the panel as follows:

1. With the WATT/VAR meter under power, remove the four screws holding the front panel to the meter, then remove the front cover and gasket.

2. Flip the small toggle on the left of the meter UP for CT set (DOWN for PT set). On the QTWIE3, the top display will show the present CT setting, and the bottom display will show the present PT setting. The negative sign will be illuminated to indicate the selected display. On WTWIE5 & RTWIE5 instruments only the selected setting (CT or PT) will be shown on the top display. All CT ratios are assumed to have 5 amps as their secondary maximum outputs. Therefore 10.0 on the display corresponds to a 10:5 CT. PTs are represented by a ratio to 1, so 20.0 on the display would correspond to a 20:1 PT. Powers of ten can also be set as the decimal point moves from left to right by using the select button.

3. Index through the available CT/PT ratios by repeatedly pushing the select button. A momentary push of the button will cause the display to increment to the next power of ten, or to the next ratio. Holding the push button down longer than 1.2 seconds will cause the watchdog timer to reset the MCU, indicated by the display test, followed by the version number of the instrument software, followed by the display of the current CT & PT ratios. This is not a problem, and can be used to reset the MCU, check for proper watchdog operation, check software version number, or return to the current CT & PT ratio. Be sure to observe the proper position of the decimal point. For ratios higher than 999, use a number expressed in "kilo", that is, the ratios should have the decimal point following the first significant digit. For example a PT of 4350:1 would use 4.35, and a CT of 3000:5 would use 3.0. Stop when you see the correct one. The table of CT ratios is listed below:

1.00, 10.0, 100.
1.10, 11.0, 110.
1.20, 12.0, 120.
1.50, 15.0, 150.
1.60, 16.0, 160.
2.00, 20.0, 200.
2.20, 22.0, 220.
2.40, 24.0, 240.
2.50, 25.0, 250.
3.00, 30.0, 300.

3.50, 35.0, 350.
4.00, 40.0, 400.
4.50, 45.0, 450.
5.00, 50.0, 500.
6.00, 60.0, 600.
7.50, 75.0, 750.
8.00, 80.0, 800.
9.00, 90.0, 900.

4. Return the toggle to the center position. You will see a digit check (1888 displayed) and the new CT ratio will be "locked" into the meter.

5. Repeat steps 2 through 4 with the CT/PT switch in the down position to set the PT ratio. A table of the PT ratios is listed below:

1.00, 10.0, 100.	
1.10, 11.0, 110.	
1.15, 11.5, 115.	relay ratio
1.20, 12.0, 120.	
1.40, 14.0, 140.	
1.50, 15.0, 150.	
1.73, 17.3, 173.	relay ratio
1.75, 17.5, 175.	
1.80, 18.0, 180.	
2.00, 20.0, 200.	
2.31, 23.1, 231.	relay ratio
2.40, 24.0, 240.	
2.50, 25.0, 250.	
2.51, 25.1, 251.	relay ratio
3.00, 30.0, 300.	
3.46, 34.6, 346.	relay ratio
3.50, 35.0, 350.	
4.00, 40.0, 400.	
4.35, 43.5, 435.	
4.50, 45.0, 450.	
5.00, 50.0, 500.	
5.77, 57.7, 577.	relay ratio
6.00, 60.0, 600.	
6.35, 63.5, 635.	
6.64, 66.4, 664.	
6.93, 69.3, 693.	relay ratio
7.00, 70.0, 700.	
8.00, 80.0, 800.	
8.08, 80.8, 808.	relay ratio

6. Replace gasket, front cover and four cover screws. Done!!

The position of the decimal point for the WATTS and/or VARs display is automatically calculated by the microcontroller; this provides up to three decades of range. With the standard Megawatt/Megavar faceplate, 19.99 to 1999 megawatts can be accommodated.

For measurements outside this range, alternate faceplates are available with units of Watts/Vars, kilowatts/kilovars, megawatts x1000/megavars x1000.

4.2 Calibration

Routine recalibration is not recommended, or required. However some drift or aging may cause slight errors after years of use. Additionally, users may wish to have a WATT/VAR meter "agree" with other instruments. To accommodate both these instances, a "Master Gain" trimpot has been provided. This trim adjusts the overall scale factor by +/-10%, and is accessed in the following manner:

1. Remove the four cover screws, and remove the front cover and gasket.
2. Remove calibration seal located in upper right-hand corner of the display board, this will allow access to the trimpot located on the Analog Processing board.
3. Insert a small screwdriver through the opening, and into the slot of the screw on the trimpot.
4. With the meter powered, AND WITH A PRECISION KNOWN INPUT, rotate the screw clockwise to increase the measurement, or counter-clockwise to decrease the indicated measurement. NOTE: Because these WATT/VAR meters are a 2 ½ element instruments, the instrument can be calibrated with a single phase source. The input voltage is limited to 75Vac in this configuration. A wiring diagram is located on page 16. When using a single phase calibration in this manner, the display should read 4 times the input signal. i.e., if you are using 50Vac and 4A, the display should read 800W with a PT setting of 1:1 and a CT setting of 5:5.
5. Remove the screwdriver, and replace the calibration seal.
6. Replace gasket, front cover and four cover screws.

The 0 to 1mA output will track the display, so recalibrating the display automatically recalibrates the 0 to 1mA output. The 0 to 1mA output cannot be calibrated independently.

4.3 Self Test Modes

The WATT/VAR instruments are based on a microcontroller, and therefore can capitalize on the power of such a device. One of the areas where the power of the microcontroller enhances the overall performance of the instrument is in the area of "self-testing". The WATT/VAR meters have several self tests built in to assure that the instrument is performing accurately. Table I on the following page lists possible faults that would be detected by the self tests, how the fault is indicated, the effects of the fault and any necessary corrective actions.

4.4 Cleaning

Cleaning the exterior of the instrument shall be limited to the wiping of the instrument using a soft damp cloth applicator with cleaning agents that are not alcohol based, and are nonflammable, nonexplosive.

TABLE I - SELF TEST RESULT SUMMARY FOR 3-PHASE WATT/VAR METERS

Fault	Fault Indication	Effects of Fault	Corrective Action
1. Display Overflow	Display flashes +1999 or -1999.	Measured quantity is too large to be displayed. Transducer output may still be accurate, if overload does not exceed transducer output ratings.	Correct fault external to instrument.
2. CT/PT ratio checksum error	Top display alternately displays 3 dashes (---) and fault code 1 (--1). On QTWIE3 bottom display displays 3 dashes (---).	Scaling of the display cannot occur due to the loss of the CT and/or PT ratios. The transducer outputs are still functional and accurate.	Attempt to reset the CT&PT ratios. If Fault continues, replace Power Supply Board and recalibrate the instrument, or replace the Base Module.
3. CT/PT board calibration checksum error	Top display alternately displays reading and fault code 2 (--2).	Calibration constants for the CT/PT Board are in error. The display and the transducer output are reduced in accuracy to approximately +/-3%.	Replace Power Supply Board and recalibrate the instrument, or replace the Base Module.
4. Analog board calibration checksum error	Top display alternately displays reading and fault code 3 (--3).	Calibration constants for the Analog Processing Board are in error. The display and the transducer output are reduced in accuracy to approximately +/-3%.	Replace Analog Processing Board or the Electronics Module.
5. Watchdog timer timeout	Both displays alternately display readings and blanks.	The watchdog timer is attempting to reset the microcontroller due to low supply voltage, or a fault in the microcontroller. Displayed values and transducer output are inaccurate.	Check input supply voltage to verify it is within specifications. If supply is OK, replace Microcontroller Board, or replace Electronics Module.

TABLE I - SELF TEST RESULT SUMMARY FOR 3-PHASE WATT/VAR METER (continued)

Fault	Fault Indication	Effects of Fault	Corrective Action
6. Input Over-Range	Top display alternately displays reading and fault code 4 (--4).	Peak input quantity exceeds the range of the instrument. Both display and transducer output accuracy reduced by an amount depending upon the degree of over-range.	Verify input signals are within range. If within range, replace analog processing board or the electronics module.
7. Program memory error	Top display indicates fault code 5 (--5) then executes power-up display sequence.	The microcontroller has detected a fault in program memory and is attempting to restart itself. Microcontroller will force transducer outputs to >2ma (0-1ma out) or 2ma (4-20ma out).	Replace microcontroller board or electronics module.
8. Analog-to-Digital converter (ADC) self-test error	Top display alternately displays 3 dashes (---) and fault code 6 (--6), other displays show 3 dashes (---).	Instrument cannot read any signals. Microcontroller will force transducer outputs to >2ma (0-1ma out) or 2ma (4-20ma out).	Replace analog processing board or the electronics module.

4.5 Electronics Module Removal

The Electronics Module consists of the Analog Processing Board (AP), the Microcontroller Board (MCU) and LED Display Board (LED). In the unlikely event of a board failure, it may be necessary to remove the Electronics Module from the instrument. Bitronics has designed the WATT/VAR meters in a modular fashion to facilitate this repair in the field, by allowing the module to be removed with the meter powered and in the panel. The procedure is as follows:

1. Remove the four screws holding the front panel to the meter, and remove the front panel and gasket.
2. Remove the two roundhead screws located at 3 o'clock and at 9 o'clock (labeled "REMOVE").
3. A wire bail is located at the top of the module, pull gently on the bail, and the Electronics Module will pull out (a slight rocking motion may be required). Be careful not to bend any of the connector pins in the Base Module. CAUTION - when the Electronics Module is removed with the instrument powered, instrument power (115Vac or 230Vac) is present on the circuit boards that remain in the Base Module. DO NOT touch or insert metallic objects into the Base Module while the instrument is powered.
4. To reinsert the Electronics Module, align the two 0.25" round guide rails with the two holes in the bottom board of the Electronics Module. Gently push the Electronics Module in until the module is fully seated (DO NOT FORCE!!).
5. Replace the two roundhead screws located at 3 o'clock and at 9 o'clock. Push the wire bail back into the meter.
6. Check CT and PT ratios and reset if necessary (See section 4.1 Rescaling).
7. Replace the gasket, front cover and four cover screws.

5.0 QUESTIONS AND ANSWERS

1. What happens if the applied CT signal exceeds 5A?

The WATT/VAR meters are accurate to twice the normal full scale limit (to 10A). The unit will operate at 100% overload without damage, however on some CT/PT settings the display will over-range, causing the display to flash with 1999. The 0-1 milliamp output is still accurate even if the display overranges, provided the load resistance is low enough to support the increased current.

2. Can modules be removed under power?

Yes. Neither input signals nor power need be disconnected to remove or rescale the Electronics Module. Removing the module DOES NOT open the CTs or PTs.

3. Is routine calibration necessary?

No, nor is it recommended. More problems are caused by improper calibration than by faulty meters. A calibration check every few years in the field is good assurance, however. If there is a question about the meter, exchanging a module may help verify performance.

4. HI and LO are marked on the inputs. Does polarity matter?

Yes! Correct wiring with proper polarity is essential for proper operation.

5. Can I put WATT/VAR meters in an outdoor cabinet?

Yes. Many Bitronics meters are installed that way. The temperature range of -20C to 70C covers most applications. The case is gasketed, but not waterproof, so it must be placed within an enclosure that provides ingress protection acceptable for the application in accordance with IEC 529, UL 840 or the equivalent NEMA Standard.

6. How long will WATT/VAR meters save the CT/PT ratio without power?

The data is saved in a nonvolatile memory (EEPROM) which does not require battery backup. Retention is estimated by the manufacturer to exceed 10 years without refreshing. In any event, long enough to exceed an outage, or for any inactive storage period.

7. I have a low voltage circuit, can I operate WATT/VAR meters without the use of CTs and PTs?

Although the WATT/VAR meter has been optimized for use with CTs and PTs, it can be connected directly to a load provided that the voltages and currents do not exceed the rating of the device. The internal CT should be set to 5 (5:5) and the internal PT should be set to 1 (120:120).

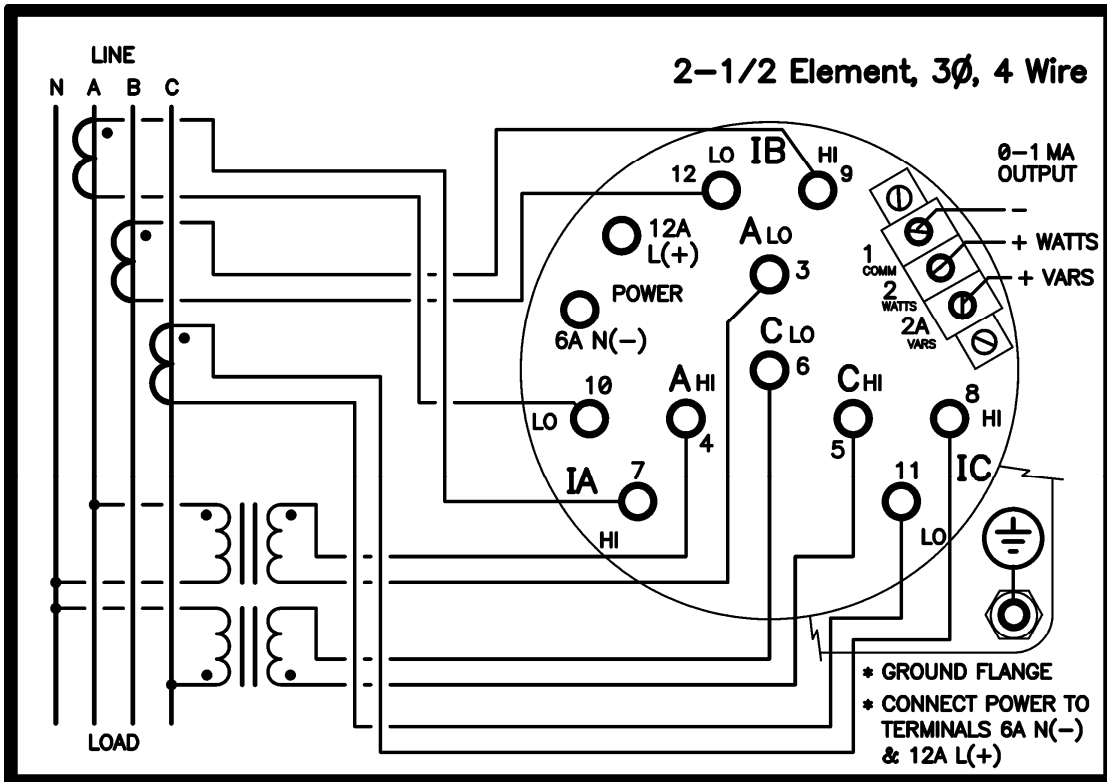

Figure 4 - Typical connection diagram for 2-1/2 Element Watt, Var & Watt/Var Meters

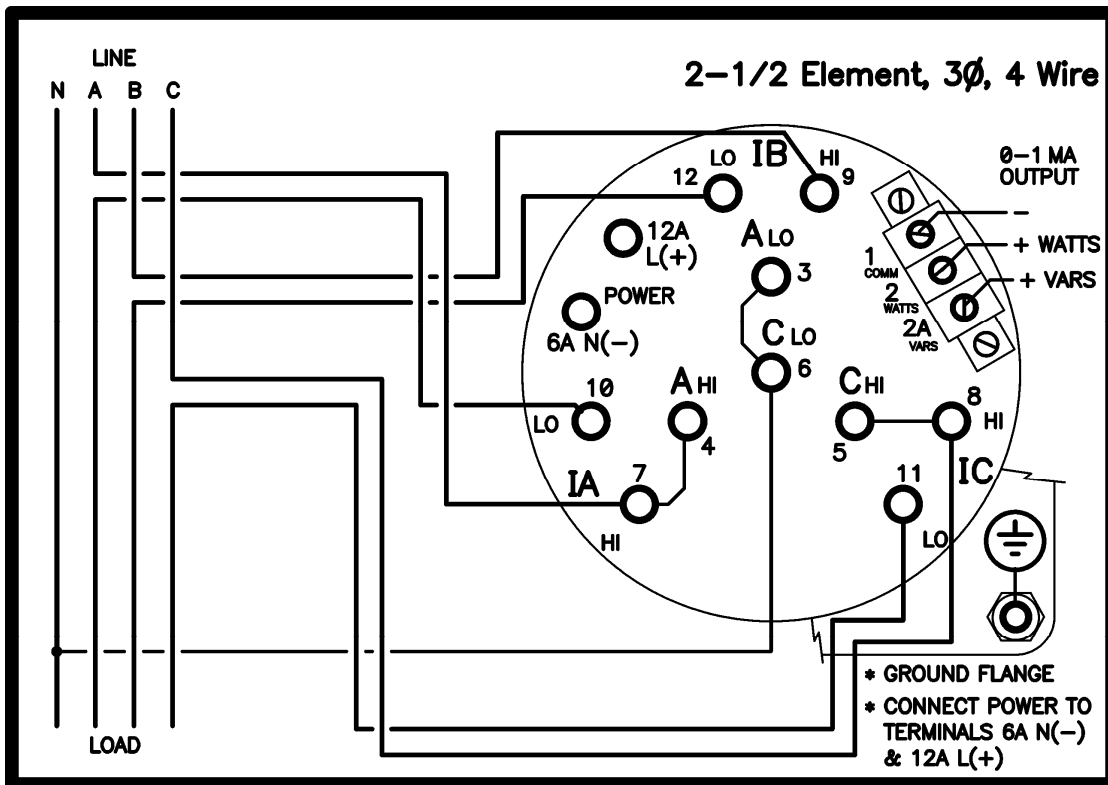

Figure 5 - Typical connection diagram for 2-1/2 Element Watt, Var & Watt/Var Meters in stand-alone mode (No CTs or Pts).

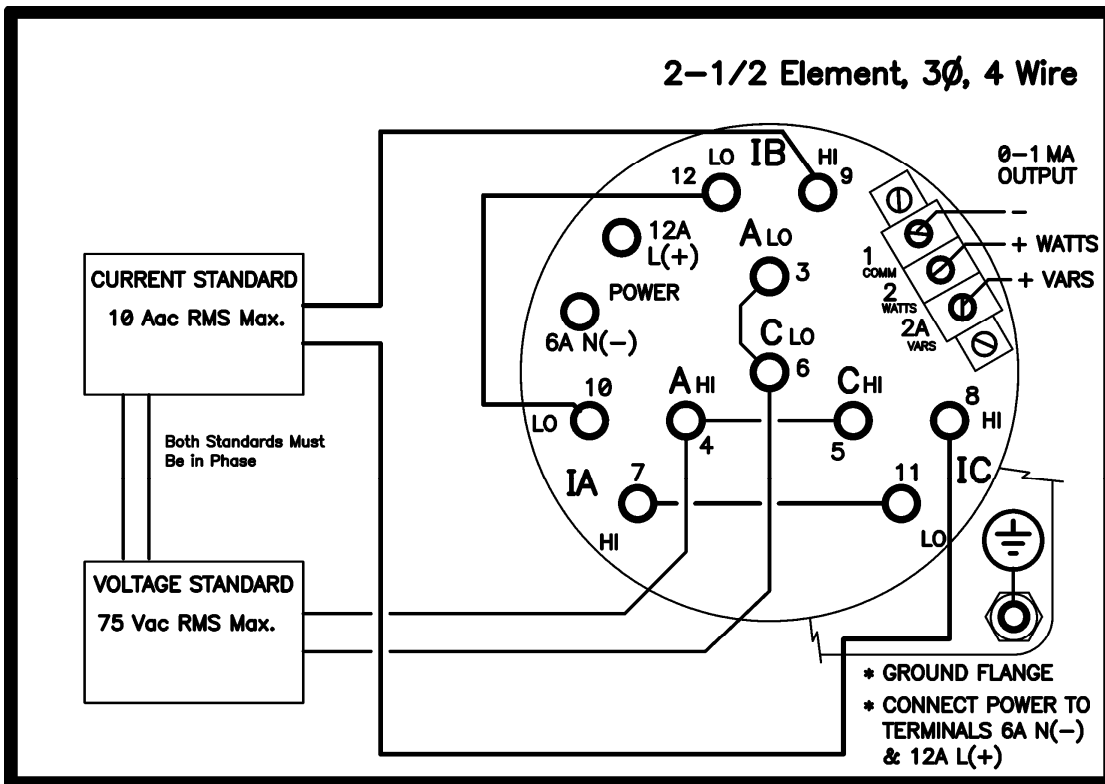

Figure 6 - Typical connection diagram for 2-1/2 Element Watt, Var & Watt/Var Meters in single phase calibration mode (note polarity of B-phase CT). PT input limited to 75Vac MAXIMUM.

Revision	Date	Changes	By
A	01/30/2009	Update Bitronics Name, Logo	E. Demicco
B	08/09/09	Updated logos and cover page	MarCom
C			



Bitronics LLC. 261 Brodhead Road, Bethlehem, PA. 18017
(610) 997-5100 Fax (610) 997-5450
www.novatechweb.com/bitronics