

**Network to 8-Channel Analog Output Converter V2  
User Manual**

August 12, 2009  
ML0011 Document Revision B  
© 2009 by Bitronics, LLC

No. NAO8101	Modbus RS-485 to 0 - +/-1mA
No. NAO8102	Modbus RS-485 to Passive 4 - 20mA
No. NAO8103	DNP3 RS-485 to 0 - +/-1mA
No. NAO8104	DNP3 RS-485 to Passive 4 - 20mA
Version 2.00	

# TABLE OF CONTENTS

TABLE OF CONTENTS .....	i
FIRMWARE REVISIONS.....	ii
CERTIFICATION .....	iii
COPYRIGHT .....	iii
INSTALLATION AND MAINTENANCE .....	iii
WARRANTY AND ASSISTANCE .....	iii
<b>1.0 DESCRIPTION .....</b>	<b>1</b>
1.1 Introduction .....	1
1.2 Features .....	2
1.3 Specifications .....	3
<b>2.0 PRINCIPLES OF OPERATION .....</b>	<b>5</b>
2.1 Construction .....	5
2.2 System Configuration.....	5
2.2.1 Direct One-to-One Connection.....	5
2.2.2 Multiple Unit Connection.....	7
2.2.3 Hybrid Network Connection.....	9
2.2.3a Requirements for External Master.....	9
2.3 Analog Outputs.....	12
<b>3.0 INSTALLATION .....</b>	<b>17</b>
3.1 Initial Inspection .....	17
3.2 Power Requirements .....	18
3.3 Grounding .....	18
3.4 Overcurrent Protection .....	18
3.5 Mains Disconnect .....	19
3.6 Instrument Mounting .....	19
3.7 Surge Protection .....	19
3.8 Setting Instrument Address .....	19
3.9 RS-485 Port Connections .....	19
<b>4.0 FIELD ADJUSTMENTS .....</b>	<b>20</b>
4.1 Calibration.....	20
4.1a NAO8101 and NAO8103.....	20
4.1b NAO8102 and NAO8104.....	20
4.2 Self Test Modes.....	21
4.3 Cleaning .....	21

## FIRMWARE REVISIONS

<u>AOC Firmware</u>	<u>Description</u>
1.00	Initial release.
1.10	Freshness timeout initialized to 10 seconds. Version 1.00 would wait 2 minutes before sending outputs to the rail after powering up AOC with no valid data (only occurred once after power up).
1.20	Incorporated smooth multiplexer channel switching algorithm.
1.30	Added support for passive 4-20mA output version (NAO8102).
1.40	Added support for non-standard Power Factor output driver.
2.00	Added support for DNP3 versions (NAO8103 and NAO8104).

## **CERTIFICATION**

Bitronics LLC certifies that the calibration of its products are based on measurements using equipment whose calibration is traceable to the United States National Institute of Standards Technology (NIST).

## **COPYRIGHT**

This Option Manual is copyrighted and all rights are reserved. The distribution and sale of this manual are intended for the use of the original purchaser or his agents. This document may not, in whole or part, be copied, photocopied, reproduced, translated or reduced to any electronic medium or machine-readable form without prior consent of Bitronics LLC, except for use by the original purchaser.

## **INSTALLATION AND MAINTENANCE**

Bitronics' products are designed for ease of installation and maintenance. As with any product of this nature, however, such installation and maintenance can present electrical hazards and should only be performed by properly trained and qualified personnel. If the equipment is used in a manner not specified by Bitronics, the protection provided by the equipment may be impaired.

## **WARRANTY AND ASSISTANCE**

Products manufactured by Bitronics LLC are warranted against defects in materials and workmanship for a period of thirty-six (36) months from the date of their original shipment from the factory. Products repaired at the factory are likewise warranted for eighteen (18) months from the date the repaired product is shipped, or for the remainder of the product's original Warranty, whichever is greater. Obligation under this warranty is limited to repairing or replacing, at Bitronics' factory, any part or parts which Bitronics' examination shows to be defective. Warranties only apply to products subject to normal use and service. There are no warranties, obligations, liabilities for consequential damages, or other liabilities on the part of Bitronics except this Warranty covering the repair of defective materials. The warranties of merchantability and fitness for a particular purpose are expressly excluded.

For assistance, contact Bitronics LLC at:

Telephone: 610.997.5100  
Fax: 610.997.5450  
Email: [bitronics@novatechps.com](mailto:bitronics@novatechps.com)  
Website: [www.novatechweb.com/bitronics](http://www.novatechweb.com/bitronics)

Shipping:  
261 Brodhead Road  
Bethlehem, PA 18017-8698  
USA

## 1.0 DESCRIPTION

### 1.1 Introduction

The Bitronics NAO8101 and NAO8103 RS-485 to 8-channel Analog Output Converters (AOC) allow Bitronics MultiComm meters and PowerPlex digital transducers to connect to traditional 0-1mA input RTUs and SCADA systems. The NAO8102 and NAO8104 models provide passive 4-20mA outputs for connection to 4-20mA SCADA systems. The NAO8101 and NAO8102 are Modbus models and are used with Bitronics MultiComm or PowerPlex instruments with RS-485 and Modbus. The NAO8103 and NAO8104 are DNP3 models and are used with Bitronics MultiComm or PowerPlex instruments with RS-485 and DNP3.0. When connected to a Bitronics MultiComm or PowerPlex with RS-485, the AOC will read the digital data from the network port of the MultiComm/PowerPlex, and drive eight 0-1mA (NAO8101 and NAO8103) or eight 4-20mA (NAO8102 and NAO8104) outputs corresponding to Total Watts, Total VARs, Per-Phase Amps, and Per-Phase Volts (or Volts L-L). Outputs corresponding to other values measured by the MultiComm/PowerPlex can be made available upon request.

A unique feature of the Bitronics AOC is that it connects to the meter/transducer over a standard RS-485 link. The AOC may be placed up to 4000ft from the source meter, allowing the AOC to be placed in the RTU cabinet, and connected to a meter located in a breaker cabinet some distance away. Instead of running wires for 8 analog signals from the meter location to the RTU, only 1 RS-485 cable needs to be run for the majority of the distance. The standard Bitronics AOC is equipped with its own Universal power supply which is capable of running on most auxiliary DC batteries, and 115AC. These features allow a great deal of flexibility and have high potential for cost savings when compared to other non-network based devices.

Bitronics AOCs take full advantage of the multidrop RS-485 communication link. Up to eight AOCs and eight MultiComm or PowerPlex instruments can be connected to the same 4000ft RS-485 link. An 8-position DIP switch on the front of the AOC is used to configure the AOC as a master or a slave, and to select which MultiComm or PowerPlex instruments to monitor or poll. The master AOC will poll all slave devices selected and will monitor the responses from the MultiComm or PowerPlex with address number 1. The slave AOC(s) will monitor the response(s) from instruments which address(es) match its switch setting.

The master AOC can be replaced by another network master such as a PLC or RTU. This Hybrid Network connection allows traditional analog SCADA systems to run concurrently with digital RTUs or PLC based Distributed Automation Systems. In this mode, the PLC or RTU network master is responsible for polling the MultiComm or PowerPlex instruments which in turn refresh the AOCs register values. The Hybrid Network connection will support up to seven standard AOCs.

## 1.2 Features

- \* Eight 0-1mA or PASSIVE 4-20mA output channels from one MultiComm or PowerPlex instrument.
- \* Modbus RTU or DNP3 protocol communications driver.
- \* Optically isolated RS-485 port.
- \* Microprocessor based design with 12-bit digital to analog converter.
- \* Operates in Master or Slave mode.
- \* Standard Universal power supply works on AC or DC service; 24, 48, 125 or 250VDC station batteries or 115VAC service.
- \* Monitors Heath-Check codes from meter / transducer to ensure validity of data.
- \* Rugged metal housing fits into existing analog transducer installations.
- \* Watchdog timer maximizes system reliability.
- \* Has built in calibration modes for verifying zero and span.
- \* Transmit and Receive LED's aid in system diagnostics.

## 1.3 Specifications

### **Models: NAO8101 and NAO8103**

Current Output :            Eight channels, 0 to +/-1mA into 10K ohms or less; Calibrated at 1mA into 5K ohms. Overload to +/-2mA into 5K ohms or less.

Output Representation: Standard Outputs (secondary)

Amps:                      0mA = 0A, 1mA = 5A

Volts:                     0mA = 0V, 1mA = 150V

Watts, VARs:            +/-1mA = +/-1000 W/VARs. (Delta Instruments)

+/-1mA = +/-1500 W/VARs (Wye Instruments)

Non-Standard Outputs (secondary)

Frequency:              0mA = 60.00Hz, +/-1mA = 61.00Hz/59.00Hz

PF:                        0mA = 1.000, +/-1mA = +/-0.000

VAs                        1mA = 1000VAs (Delta) or 1500VAs (Wye)

Accuracy:                0.25% Class (ANSI Std 460-1988).

Voltage Isolation:      2500Vac from Power to Port or Outputs.  
1500Vac from Port to Outputs.

Communications Protocol: Modbus RTU (NAO8101) or DNP3 (NAO8103).

Data update rate: New data available every (70msec) X (# NAO8101 units present)  
New data available every (100msec) X (# NAO8103 units present)  
(Note: 100msec valid if no flags are being sent by instrument)

Delay from Input to Meter: 150msec. + 70msec. per polled meter for NAO8101  
150msec. + 100msec per polled meter for NAO8103.  
(plus 450msec when used with non -"B" Series meters/transducers)

Power Requirements: Universal 55-200 Vac or 20-280 Vdc, 6 Watts  
230 Vac optional

Fuse: 1.5 Ampere, non-time delay (M) fuse, UL listed located in the ungrounded (hot) side of the line, external to meter.

Operating Temperature: -30C to 70C.  
Humidity: 0-95% non-condensing

Installation Category: IC III (Distribution Level)  
Pollution Degree: 2

Weight: 2.5 pounds ( 1.60 kilograms )

Size: 5.25"H x 5.60"W x 5.63"D

### **Models: NAO8102 and NAO8104**

Current Output : Eight channels, passive 4-20mA. Unidirectional quantities are calibrated at 4mA and 20mA. Bidirectional quantities are calibrated at 4mA, 12mA and 20mA where 12mA is the zero reference.

Max. Loop Voltage: 40Vdc

Max. Voltage Drop: 5V @ 20mA

#### Output Representation: Standard Outputs (secondary)

Amps: 4mA = 0A, 20mA = 5A

Volts: 4mA = 0V, 20mA = 150V

Watts,VARs: 4mA/20mA = +/-1000 W/VARs. (Delta Instrmnts)

4mA/20mA = +/-1500 W/VARs (Wye Instrmnts)

#### Non-Standard Outputs (secondary)

Frequency: 12mA = 60.00Hz, 4mA/20mA = 59.00/61.00Hz

PF: 12mA = 1.000, 4mA/20mA = -0.000/+0.000

VAs 12mA = 0 VAs

20mA = 1000VAs (Delta) or 1500VAs (Wye)

Accuracy: 0.25% Class (ANSI Std 460-1988).

Voltage Isolation: 2500Vac from Power to Port or Outputs.  
1500Vac from Port to Outputs.

Communications Protocol: Modbus RTU (NAO8102) or DNP3 (NAO8104).

Data update rate: New data available every (70msec) X (# NAO8102 units present)  
New data available every (100msec)X (# NAO8104 units present)  
*(Note: 100msec valid if no flags are being sent by instrument)*

Delay from Input to Meter: 150msec. + 70msec. per polled meter for NAO8102  
150msec. + 100msec per polled meter for NAO8104.  
*(plus 450msec when used with non -"B" Series meters/transducers)*

Power Requirements: Universal 55-200 Vac or 20-280 Vdc, 6 Watts (230 Vac optional)

Fuse: 1.5 Ampere, non-time delay (M) fuse, UL listed located in the ungrounded (hot) side of the line, external to meter.

Operating Temperature: -20C to 70C.

Installation Category: IC III (Distribution Level)  
Pollution Degree: 2

Weight: 2.5 pounds ( 1.60 kilograms )

Size: 5.25"H x 5.60"W x 5.63"D



## **2.0 PRINCIPLES OF OPERATION**

### **2.1 Construction**

The Bitronics Analog Output Converter is composed of three Printed Circuit Board Assemblies and a Back Panel. The three Circuit Board Assemblies include the Analog Output and Port Board, the Processor Board, and the Power Supply Board.

### **2.2 System Configuration**

There are three different types of systems that the AOC can be integrated into. They are the Direct One-to-One connection, the Multiple Unit connection, and the Hybrid Network connection. These systems and their respective connections are described in detail below.

#### **2.2.1 Direct One-to-One Connection**

In the most basic connection, one AOC can be connected to one MultiComm or PowerPlex instrument via the RS-485 port. Refer to Sec. 3.9 for the RS-485 Connections. The chief advantage of this connection is that it has the fastest update rate. MultiComm and PowerPlex units provide fresh data every 150ms (600ms for pre “B” series units). With a direct one-to-one connection, the AOC will poll the meter/transducer, receive a response, and update its outputs every 75ms to 100ms. Therefore, the data represented by the analog outputs will be at most 250ms (700ms when connected to a pre “B” series meter/transducer) old. The AOC may be placed up to 4000ft from the meter/transducer. The wiring between the two devices consists of an RS-485 cable which reduces wiring between the metering point and the analog input device.

For operation in this mode, locate SW1 on the front panel behind the clear window. SW1 switch 1 (MASTER) must be in the ON (upward) position, with the ACTIVE SLAVE(S) switches all in the OFF (downward) position. Figure 1 shows the connection concept and DIP switch settings. Set the MultiComm or PowerPlex address switch to 1. The front panel LED marked TXD will flash each time the AOC requests data from the meter/transducer, and the LED marked RXD will flash each time the AOC receives valid data from the meter/transducer.

The AOC polls and receives a Health Check register from the MultiComm/PowerPlex instrument, and uses it to verify the validity of the data (see Section 4.2). If the data is determined to be faulty, the 0-1mA outputs are driven to maximum positive full scale (approximately 2.5mA). In addition, if the AOC does not receive fresh data for a given output channel within 10 seconds, the unit will drive the 0-1mA output for the appropriate output channel to maximum positive full scale (approximately 2.5mA). Units with 4-20mA outputs drive the output to 2mA under these conditions. Upon power-up of the AOC, the analog outputs are driven to 0mA (or the appropriate zero level for 4-20mA units). If fresh valid data is received within 10sec, the outputs will respond by moving to the appropriate level. If no data has been received after 10sec, the AOC will time-out as described above. DNP3 data received with the ONLINE flag clear is not considered fresh data (refer to the instruments DNP3 Interface Option Manual for a more detailed description of DNP3 data flags).

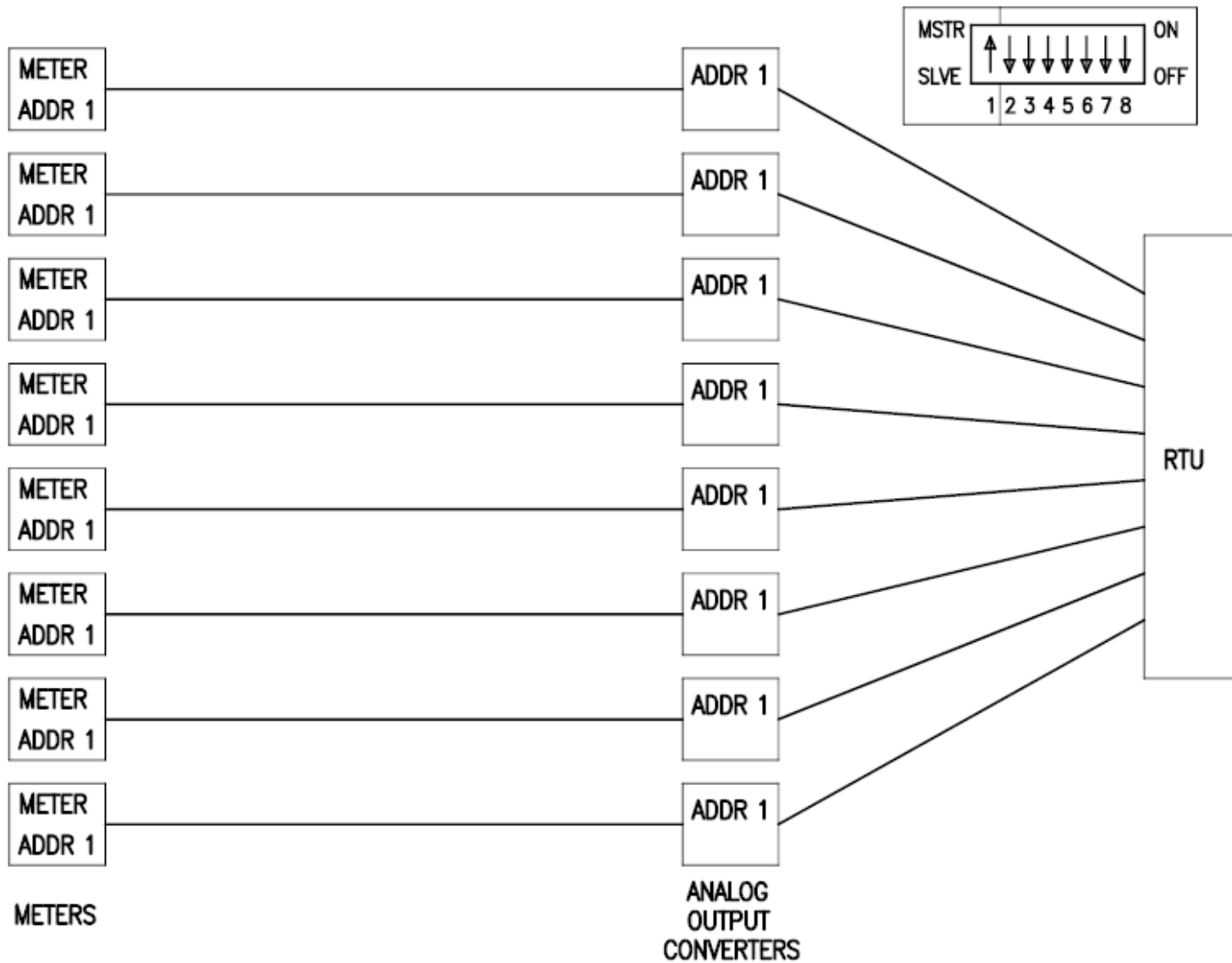

Figure 1 - Direct One-to-One Connection

## 2.2.2 Multiple Unit Connection

The Multiple Unit Connection allows up to eight MultiComm/PowerPlex units and eight AOCs to be connected on one RS-485 circuit. Refer to Sec. 3.9 for RS-485 Connections. A requirement of a master/slave protocol is that a network may have only one device that initiates requests for data (the MASTER). To accommodate this requirement, one of the AOC units functions as the system MASTER. The MASTER AOC has SW1 switch #1 in the ON (upward) position, and polls the meter/transducer set to address 1. The MASTER drives its analog outputs based on the data it received from the meter/transducer set to address 1. The MASTER AOC will also poll up to seven other instruments (addresses 2 through 8) depending on the settings of SW1 switches 2 through 8. Placing any of the ACTIVE SLAVE switches in the ON position causes the MASTER AOC to poll that respective meter/transducer in addition to the meter/transducer at address 1. The MASTER AOC does not use the data from the meters/transducers set to addresses other than 1, that data is received by the AOCs in SLAVE mode set to that respective address.

SLAVE AOC's function as "passive listeners", and update their outputs to correspond to the data from the meter/transducer with the same address as the AOC SLAVE address. All SLAVE AOC's have SW1 switch 1 in the OFF (downward) position, and at most *one* ACTIVE SLAVE(S) switch in the ON (upward) position. Figure 2 shows the connection concept and DIP switch settings. If multiple ACTIVE SLAVE switches are ON (UP), the AOC will ignore all data and drive all outputs to the error condition (approximately 2.5mA for NAO8101 and NAO8103 models, approximately 2mA for NAO8102 and NAO8104 models).

The front panel indicator LED marked TXD will flash only on AOCs in MASTER mode when the MASTER AOC polls any meter/transducer for data. The LED marked RXD will flash on any unit when that AOC receives valid data corresponding to any of its output channels from the meter/transducer with a matching address. For example, a SLAVE AOC with only SW1 switch 3 in the ON (upward) position will flash its RXD LED when the meter/transducer set to address 3 responds to its data poll, but not when any other meter/transducer address responds.

The AOC polls and receives a Health Check register from the MultiComm/PowerPlex instrument, and uses it to verify the validity of the data (see Section 4.2). If the data is determined to be faulty, the 0-1mA outputs are driven to maximum positive full scale (approximately 2.5mA). In addition, if the AOC does not receive fresh data for a given output channel within 10 seconds, the unit will drive the 0-1mA output for the appropriate output channel to maximum positive full scale (approximately 2.5mA). Units with 4-20mA outputs drive the output to 2mA under these conditions. Upon power-up of the AOC, the analog outputs are driven to 0mA (or the appropriate zero level for 4-20mA units). If fresh valid data is received within 10sec, the outputs will respond by moving to the appropriate level. If no data has been received after 10sec, the AOC will time-out as described above. DNP3 data received with the ONLINE flag clear is not considered fresh data (refer to the instruments DNP3 Interface Option Manual for a more detailed description of DNP3 data flags).

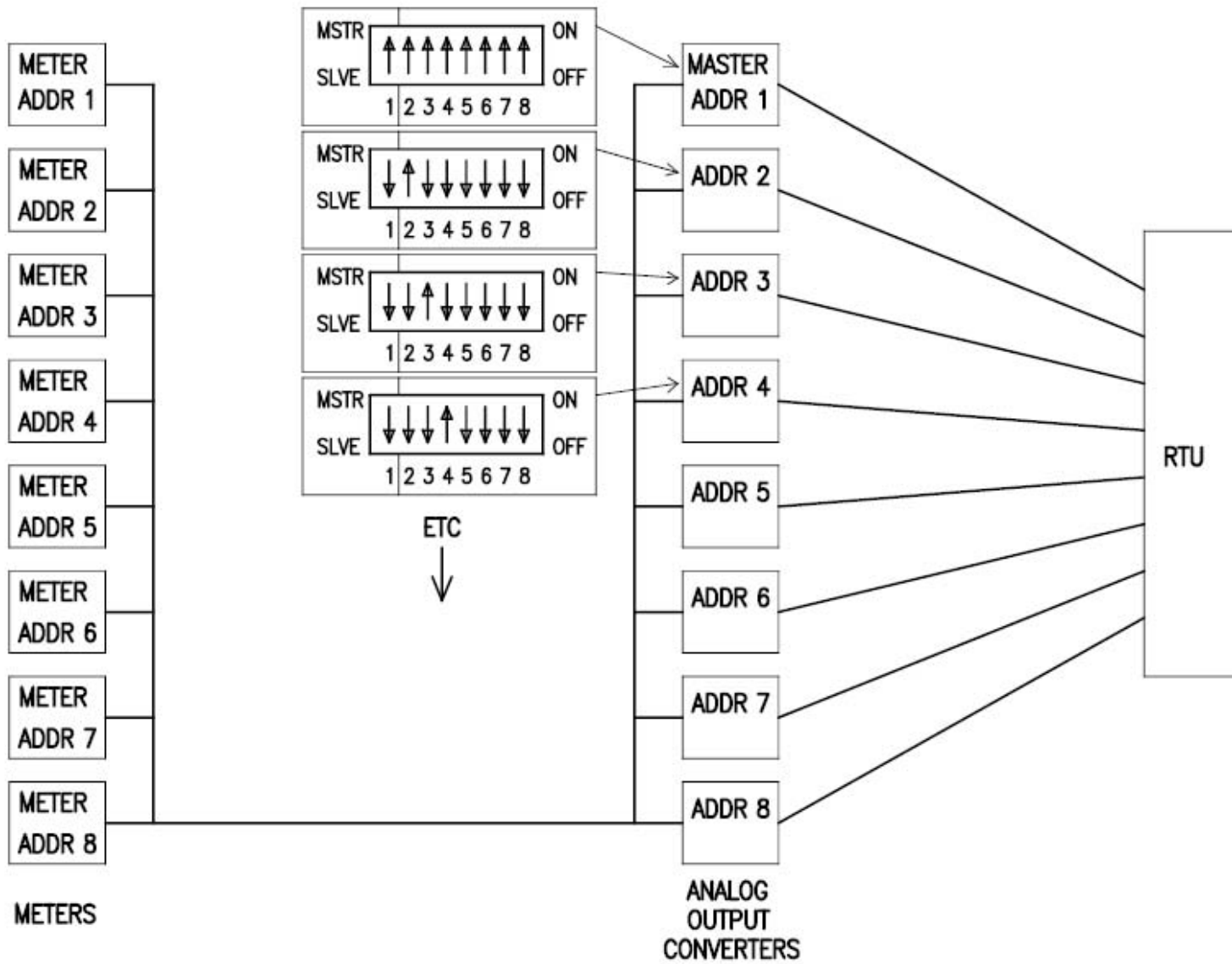

Figure 2 - Multiple Unit Connection

### 2.2.3 Hybrid Network Connection

The Hybrid Network connection is very similar to the Multiple Unit connection, except that the MASTER AOC is replaced by another device (the EXTERNAL MASTER). Up to seven standard SLAVE AOCs can be connected in this manner. Refer to Sec. 3.9 for RS-485 Connections. The EXTERNAL MASTER is free to perform other functions on the network, such as communicate with other devices, or request additional data from the MultiComm/PowerPlex units. The SLAVE AOCs are factory configured to monitor specific data registers from a single meter/transducer address, and will ignore messages or data from all other devices or registers. Figure 3 shows the connection concept and DIP switch settings. *There are specific requirements on the device serving as the EXTERNAL MASTER for this connection to work properly. See section 2.2.3a for details.*

The front panel LED marked TXD should not flash on any of the AOC units in this connection, as none is operating as a master. The LED marked RXD will flash on an AOC when that AOC receives data from the meter/transducer with a matching address. For example, a SLAVE AOC with only SW1 switch 3 in the ON (upward) position will flash its RXD LED when the meter/transducer set to address 3 responds to its data poll, but not when any other meter/transducer address responds.

#### 2.2.3a Requirements for External Master

Standard AOCs will time out and drive any analog output to indicate an error condition (see below) if it does not receive fresh data for that output within 10sec. If it is required to maintain uninterrupted analog output data, then the following rule must be followed:

The EXTERNAL MASTER must request fresh data (from Holding Registers 40001 through 40009 for standard NAO8101 and NAO8102 models; or from Analog Inputs 0 through 8 for standard NAO8103 and NAO8104 models) for each AOC meter/transducer address present, every 10sec or less. See Tables 1 and 2 for typical standard register assignments. Refer to the Modbus RTU Interface or the DNP3 Interface Option Manual supplied with the MultiComm or PowerPlex unit. Reads from other registers and other devices along with other network traffic may also occur as long as the above rule is followed.

Special order non-standard AOCs may provide additional outputs and require that additional registers be polled. These non-standard AOCs may also be configured for an extended timeout for fresh data. Please make sure that the version number on the AOC matches the version number on the front of this manual.

In some implementations, it may not be undesirable for the AOC analog outputs to time out. In these systems, the EXTERNAL MASTER must read the required registers to refresh the data at least 250msec (750msec for pre-"B" Series MultiComm/PowerPlex units) before the AOC output channel is read.

Master AOCs poll and receive a Health Check register from the MultiComm/PowerPlex instrument, and use it to verify the validity of the data (see Section 4.2). If the EXTERNAL MASTER does not poll the Health Check register (Modbus Register 40001 or DNP3 Analog Point 0) the SLAVE AOCs will assume that all data received is valid. For this reason, it is strongly recommended that EXTERNAL MASTER devices poll the HEALTH CHECK registers.

If the data is determined to be faulty or the AOC does not receive fresh data for a given output channel within 10 seconds, the 0-1mA outputs are driven to maximum positive full scale (approximately 2.5mA). Units with 4-20mA outputs drive the output to 2mA under these conditions. Upon power-up of the AOC, the analog outputs are driven to 0mA (or the appropriate zero level for 4-20mA units). If fresh valid data is received within 10sec, the outputs will respond by moving to the appropriate level. If no data has been received after 10sec, the AOC will time-out as described above. DNP3 data received with the ONLINE flag clear is not considered fresh data (refer to the instruments DNP3 Interface Option Manual for a more detailed description of DNP3 data flags)

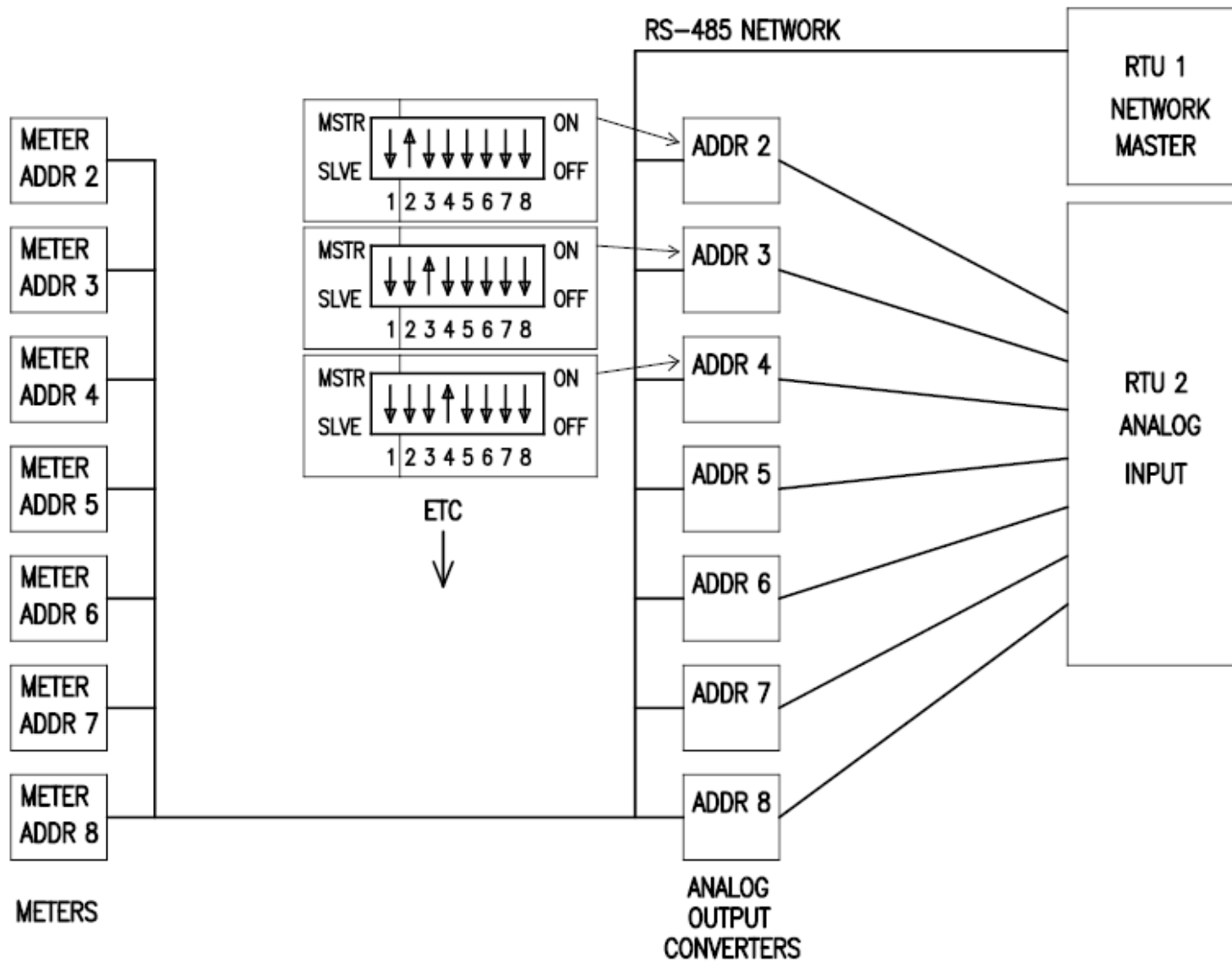

Figure 3 - Hybrid Network Connection

## 2.3 Analog Outputs

The NAO8101 and NAO8103 models have eight 0 to +/-1mA analog outputs, marked A1 through A8, capable of driving 1mA into 10K ohms or 2mA into 5K ohms (10V load compliance). The outputs are assigned to fixed registers as shown in Figure 6. The output connection is shown in Figure 4. Other assignments are available on special order, please consult the factory for more information. For units with non-standard output assignments, refer to label on unit. Both terminals marked COM are internally connected, and are to be used as the signal return.

The NAO8102 and NAO8104 models have eight passive 4 to 20mA analog outputs, marked A1 through A8, capable of driving up to 25mA with an external loop supply of up to 40Vdc, and a voltage drop of up to 5V @ 20mA. The outputs are assigned to fixed registers as shown in Figure 6. The output connection is shown in Figure 5. Other assignments are available on special order; please consult the factory for more information. For units with non-standard output assignments, refer to label on unit. Both terminals marked COM are internally connected, and are to be used as the signal return.

If the AOC does not receive data over the RS-485 connection for a given output channel within 10 seconds, the unit will drive the 0-1mA output for the appropriate output channel to maximum positive full scale (approximately 2.5mA). Units with 4-20mA outputs drive the output to 2mA under these conditions. Upon power-up of the AOC, the analog outputs are driven to 0mA (or the appropriate zero level for 4-20mA units). If valid data is received within 10sec, the outputs will respond by moving to the appropriate level. If no data has been received after 10sec, the AOC will time-out as described above.



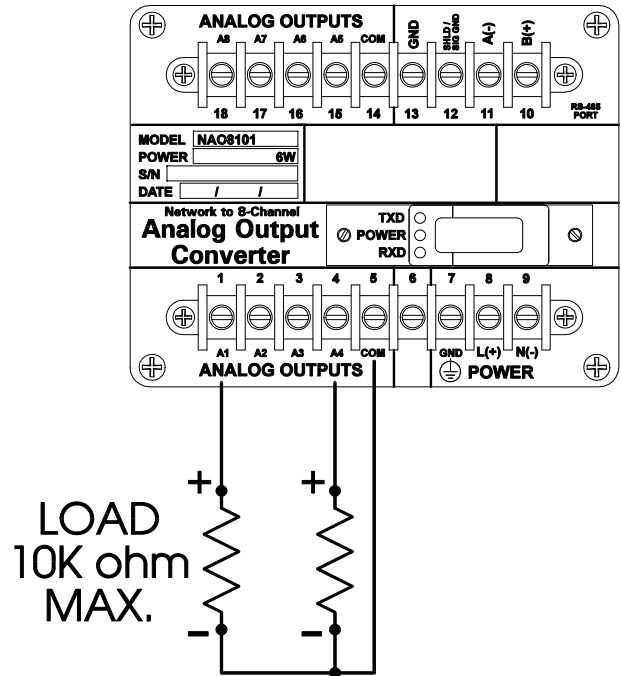

Figure 4: NAO8101 and NAO8103 0-1 mA Output Connections

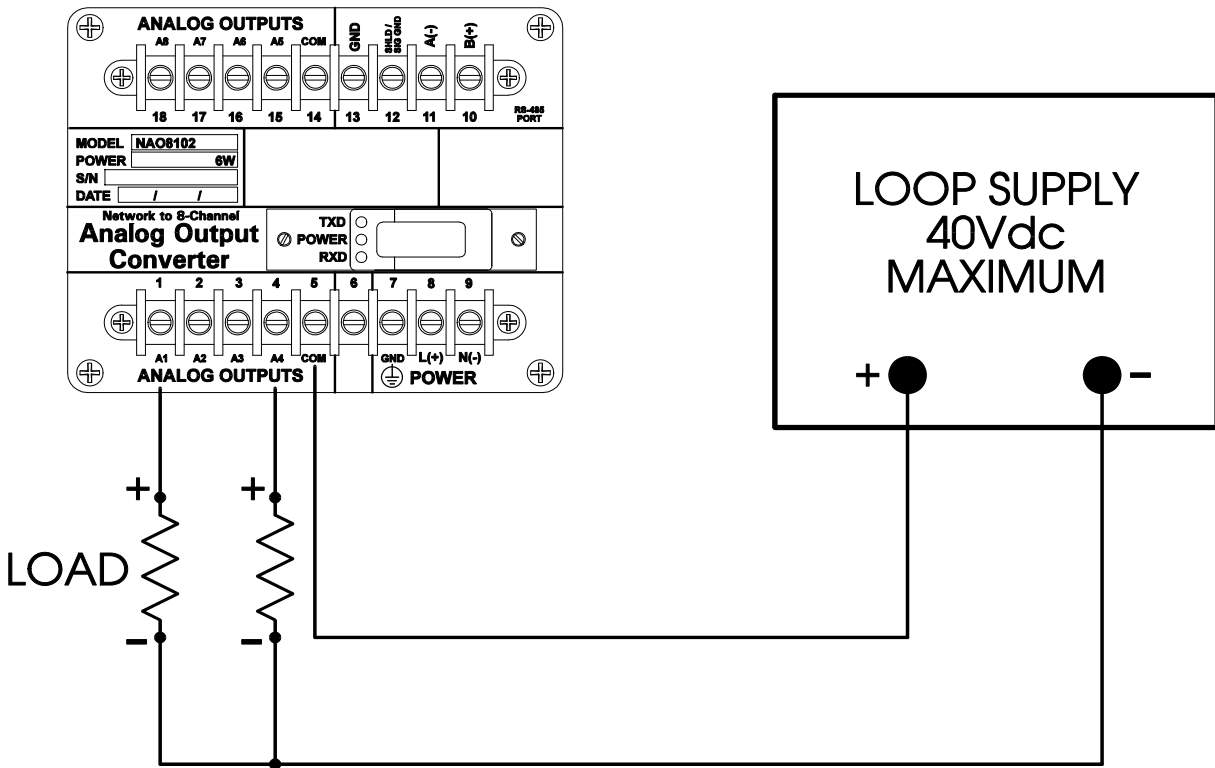
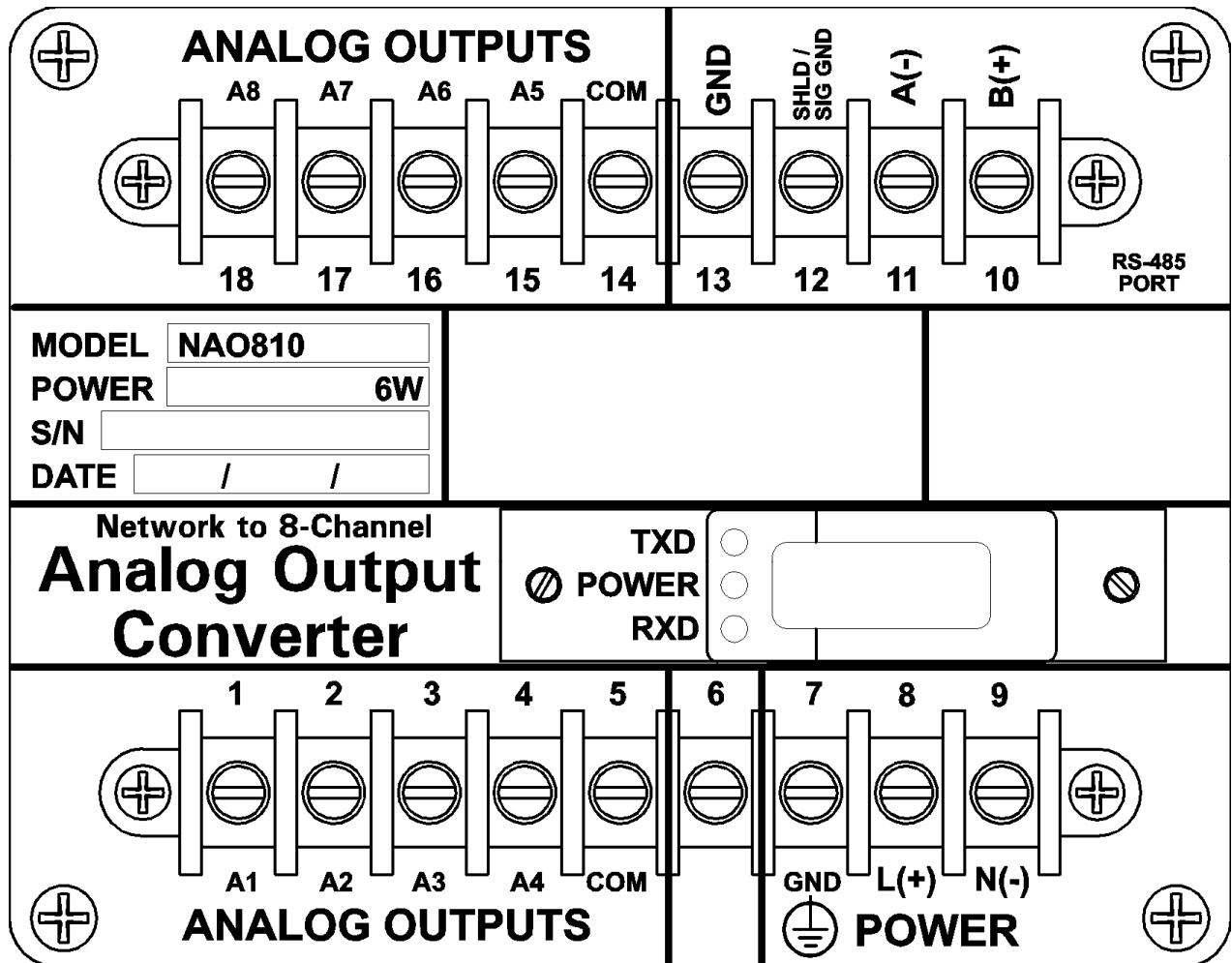

Figure 5: NAO8102 and NAO8104 4-20 mA Output Connections



OUTPUT	QUANTITY	OUTPUT	QUANTITY
A1	TOTAL VARS	A5	C PHASE VOLTS
A2	A PHASE AMPS	A6	B PHASE VOLTS
A3	B PHASE AMPS	A7	A PHASE VOLTS
A4	C PHASE AMPS	A8	TOTAL WATTS

**ALL OUTPUTS REFERENCED TO COMMON.  
 TERMINALS 5 & 14 (COMMON) ARE INTERNALLY CONECTED.**

Figure 6 - Standard Analog Output Assignments

**TABLE 1: NAO8101 and NAO8102 Holding Registers**

**MODBUS MULTICOMM / POWERPLEX 2-1/2 & 3 ELEMENT (WYE) DATA REGISTER ASSIGNMENTS**

Quantity	Holding Register	Representation
Health Check	40001	Refer to Section 3.7 (in Modbus Interface Options Manual)
Amperes Phase A	40002	 2047 = 0Amps; 4095 = 10.0Amps
Amperes Phase B	40003	
Amperes Phase C	40004	
Volts Phase A-N	40005	 2047 = 0Volts; 4095 = 150.0Volts
Volts Phase B-N	40006	
Volts Phase C-N	40007	
Watts Total 3 Phase	40008	0 = -3000Watts; 2047 = 0Watts; 4095 = +3000Watts
VARs Total 3 Phase	40009	0 = -3000VARs; 2047 = 0VARs; 4095 = +3000VARs

**MODBUS MULTICOMM / POWERPLEX 2 ELEMENT (DELTA) DATA REGISTER ASSIGNMENTS**

Quantity	Holding Register	Representation
Health Check	40001	Refer to Section 3.7 (in Modbus Interface Options Manual)
Amperes Phase A	40002	 2047 = 0Amps; 4095 = 10.0Amps
Amperes Phase B	40003	
Amperes Phase C	40004	
Volts Phase A-B	40005	 2047 = 0Volts; 4095 = 150.0Volts
Volts Phase B-C	40006	
Volts Phase C-A	40007	
Watts Total 3 Phase	40008	0 = -2000Watts; 2047 = 0Watts; 4095 = +2000Watts
VARs Total 3 Phase	40009	0 = -2000VARs; 2047 = 0VARs; 4095 = +2000VARs

**TABLE 2: NAO8103 and NAO8104 Analog Input Points**

**DNP3 MULTICOMM / POWERPLEX 2-1/2 & 3 ELEMENT (WYE) DATA REGISTER ASSIGNMENTS**

Quantity	Object: Point	Representation
Health Check	A:0	Refer to Section 3.7 (in DNP3 Interface Options Manual)
Amperes Phase A	A:1	 0 = 0Amps; 32767 = 10.0Amps 
Amperes Phase B	A:2	
Amperes Phase C	A:3	
Volts Phase A-N	A:4	 0 = 0Volts; 32767 = 150.0Volts 
Volts Phase B-N	A:5	
Volts Phase C-N	A:6	
Watts Total 3 Phase	A:7	-32768 = -4500Watts; 0 = 0Watts; 32767 = +4500Watts
VARs Total 3 Phase	A:8	-32767 = -4500VARs; 0 = 0VARs; 32768 = +4500VARs

**DNP3 MULTICOMM / POWERPLEX 2 ELEMENT (DELTA) DATA REGISTER ASSIGNMENTS**

Quantity	Object: Point	Representation
Health Check	A:0	Refer to Section 3.7 (in DNP3 Interface Options Manual)
Amperes Phase A	A:1	 0 = 0Amps; 32767 = 10.0Amps 
Amperes Phase B	A:2	
Amperes Phase C	A:3	
Volts Phase A-B	A:4	 0 = 0Volts; 32767 = 150.0Volts 
Volts Phase B-C	A:5	
Volts Phase C-A	A:6	
Watts Total 3 Phase	A:7	-32768 = -3000Watts; 0 = 0Watts; 32767 = +3000Watts
VARs Total 3 Phase	A:8	-32768 = -3000VARs; 0 = 0VARs; 32767 = +3000VARs

### 3.0 INSTALLATION



WARNING - INSTALLATION AND MAINTENANCE SHOULD ONLY BE PERFORMED BY PROPERLY TRAINED OR QUALIFIED PERSONNEL.

### 3.1 Initial Inspection

Bitronics' instruments are carefully checked and "burned in" at the factory before shipment. Damages can occur, however, so please check the instrument for shipping damage as it is unpacked. Notify Bitronics immediately if any damage has occurred, and save any damaged shipping containers.

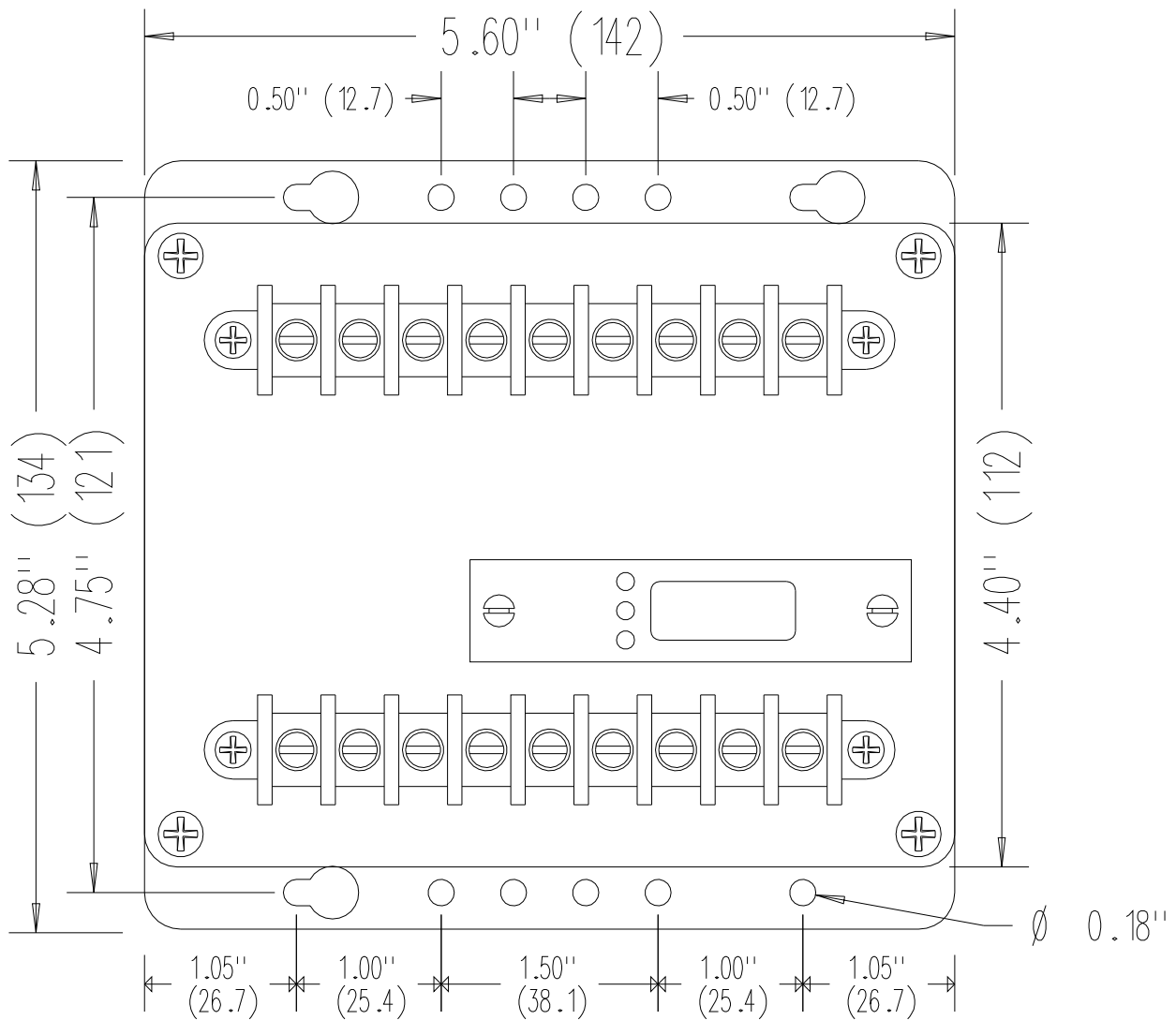
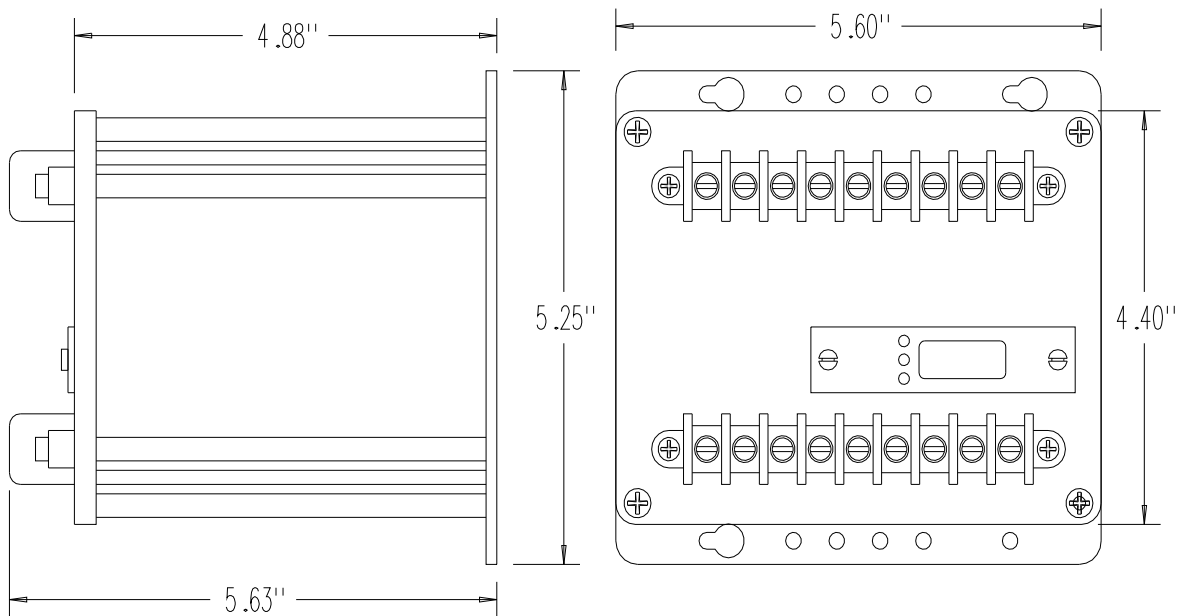

Figure 7 – Mounting Dimensions



**Figure 8 – Outside Dimensions**

### 3.2 Power Requirements

Bitronics Analog Output Converters are normally equipped with Universal (AC/DC) power supplies. Power is connected to the two labeled terminals on the front panel. Both terminals are electrically isolated from the meter case and from the electronic circuitry. Variations of the auxiliary supply voltage that are within the supply specifications will not affect the performance of the instrument. The power supply and regulators provide constant dc power to the boards independent of variations in auxiliary supply voltage over this range.

### 3.3 Grounding

There are two chassis ground points that **MUST** be connected to Earth Ground. One is terminal #7 (next to the Power inputs), and the other is the transducer mounting flange. All grounding is recommended to be performed in accordance with ANSI/IEEE C57.13.3-1983. The Ground terminal #7 is connected to the Line (+) terminal #8 through a 0.01uF UL listed capacitor, not with an MOV, in order to preserve ground isolation when the unit is operated from DC station battery service.

### 3.4 Overcurrent Protection

A UL recognized 1.5 Ampere non-time delay (M) fuse is to be series connected in the ungrounded (hot) side of mains input as part of installation of this product.

### **3.5 Mains Disconnect**

Equipment shall be provided with a Mains Disconnect, that can be actuated by the operator and simultaneously open both sides of the mains input line. The Disconnect shall be UL Recognized and acceptable for the application.

### **3.6 Instrument Mounting**

The instrument may be mounted on a standard transducer mounting hole pattern if desired. See Figure 7. The unit should be mounted with four #8-32 screws. The transducer is intended to be connected to earth ground at the mounting plate. See section 3.3.

### **3.7 Surge Protection**

It is recommended that a metal oxide varistor (MOV) be placed across the power supply input to protect the instrument in the event of high voltage surges or lightning strikes. Analog Output Converters are shipped with a transient suppression network already attached as a standard design. An MOV provides an added measure of protection against heavy switching transients occasionally experienced in the field. The MOV is designed to clamp applied power voltages above 270 V ac RMS. A single MOV protects the unit Line to Line, and a high voltage capacitor is provided to protect from Line to Ground. To avoid damaging the MOV protector, maintain continuously applied power voltages within the ratings of the instrument. The mounting flange is a safety ground for the instrument, and must be connected to a protective earth circuit. Mounting of the MOV board external to the instrument allows easy access so that the MOV and Cap may be readily inspected for damage. If the unit is to be powered from a PT, it is recommended that one side of the PT be grounded at the instrument following ANSI/IEEE C57.13.3-1983. The MOV board voltage rating is indicated on the MOV board, and must match the voltage supply rating of the instrument.

### **3.8 Setting Instrument Address**

All AOC's require that the front panel switches be set properly before any communications can begin. Refer to Section 2 for setup instructions.

### **3.9 RS-485 Port Connections**

RS-485 is a multi-drop network topology. Wires from one unit must be connected to like terminals of other units (ie. A(-) to A(-), B(+) to B(+), SHLD to SHLD). The GND terminal should be connected to Ground at exactly one point in the system.

## 4.0 FIELD ADJUSTMENTS



WARNING - INSTALLATION AND MAINTENANCE SHOULD ONLY BE PERFORMED BY PROPERLY TRAINED OR QUALIFIED PERSONNEL.

### 4.1 Calibration

Routine recalibration is not recommended, or required. However some drift or aging may cause slight errors after years of use.

#### 4.1a NAO8101 and NAO8103

To allow easy field calibration, both a span and zero trimpot have been provided. By using the front panel switch (SW1), the AOC may be placed into two different calibration modes, one for zero and one for span. These adjustments affect all eight channels simultaneously, and are accessed in the following manner:

1. Remove the two screws on the front of the unit, and remove the clear plastic cover. Record the settings of SW1 for later use.
2. Set all SW1 switches to the OFF (DOWN) position. This will cause the AOC to drive all eight outputs to 0mA. Connect all outputs (A1 through A8) together, and through a precision DC milliammeter to the terminal marked COM. Turn the trimpot marked ZERO until the summed output of all channels reads 0mA on the DC milliammeter.
3. Move SW1 switches 2 through 8 to the ON (UP) position. Switch 1 remains in the OFF (DOWN) position. This will cause the AOC to drive each of the eight outputs to 1mA. Connect all outputs (A1 through A8) together, and through a precision DC milliammeter to the terminal marked COM. Turn the trimpot marked SPAN until the summed output of all channels reads 8mA on the DC milliammeter.
4. Connect each output (A1 through A8) individually, and, using the switch setting from steps 2 & 3, check each output to verify the outputs at 0mA and 1mA.
5. Reset SW1 to its original setting, and re-install the clear cover. Done!

#### 4.1b NAO8102 and NAO8104

Refer to Figure 4 for connection information. To allow easy field calibration, a span trimpot has been provided. By using the front panel switch (SW1), the AOC may be placed into two different calibration modes, one for 4mA and one for 20mA. These adjustments affect all eight channels simultaneously, and are accessed in the following manner:

1. Remove the two screws on the front of the unit, and remove the clear plastic cover. Record the settings of SW1 for later use.
2. Move SW1 switches 2 through 8 to the ON (UP) position. Move Switch 1 to the OFF (DOWN) position. This will cause the AOC to drive each of the eight outputs to 20mA. Connect all outputs (A1 through A8) together, and through a precision DC milliammeter to



the terminal marked COM. Turn the trimpot marked SPAN until the summed output of all channels reads 160mA on the DC milliammeter.

3. Set all SW1 switches to the OFF (DOWN) position. This will cause the AOC to drive all eight outputs to 4mA. Connect all outputs (A1 through A8) together, and through a precision DC milliammeter to the terminal marked COM. Verify that the summed output of all channels reads 32mA on the DC milliammeter.
4. Connect each output (A1 through A8) individually, and, using the switch setting from steps 2 & 3, check each output to verify the outputs at 4mA and 20mA.
5. Reset SW1 to its original setting, and re-install the clear cover. Done!

## **4.2 Self Test Modes**

Bitronics MultiComm/PowerPlex instruments are based on a microcontroller, and therefore can capitalize on the power of such a device. One of the areas where the power of the microcontroller enhances the overall performance of the instrument is in the area of "self-testing." These meters/transducers have several self tests built in to assure that the instrument is performing accurately. If problems are detected during self test, the appropriate error code is transmitted over the network. See the Modbus RTU Interface or the DNP3 Interface Options manual shipped with your meter/transducer for details. Table I in the appropriate output option manual lists possible faults that would be detected by the self tests, the effects of the fault, and any necessary corrective actions. The AOC will request data from the Health Check register from each device when operating as a master. All AOC's will then monitor the Health Check register (Modbus Holding Register 40001 or DNP3 Analog Input Point 0) to verify the validity of the data. If an AOC reads a Health Check code corresponding to an Analog-to-Digital Converter Self Test Error or a Program Memory Failure, it will drive all outputs to about 2.5mA (2mA for 4-20mA units) to indicate the problem. All other Health Check codes are ignored..

## **4.3 Cleaning**

Cleaning the exterior of the instrument shall be limited to the wiping of the instrument using a soft damp cloth applicator with cleaning agents that are not alcohol based, and are nonflammable, nonexplosive.

Revision	Date	Changes	By
A	01/30/2009	Update Bitronics Name, Logo	E. Demicco
B	08/09/09	Updated logos and cover page	MarCom
C			



Bitronics LLC. 261 Brodhead Road, Bethlehem, PA. 18017  
(610) 997-5100 Fax (610) 997-5450  
[www.novatechweb.com/bitronics](http://www.novatechweb.com/bitronics)