

The Bitronics MultiComm instrument is a utility-grade, three-phase, digital power meter that connects directly to instrument transformers. Direct-connect high-voltage inputs are also available.

The design and components are field-proven in the substation environment with all inputs transformer isolated. The multiple microprocessor design uses advanced digital signal processing for true RMS measurements including power. This instrument is a multifunction meter that calculates and displays Voltages, Currents, Power (real, reactive, apparent), Power Factor, Frequency, and Energy Values. Real-time Harmonics, K-Factor, Displacement Power Factor, and Demand measurements with Min/Max memory are also available.

The Bitronics MultiComm instrument is an Intelligent Electronic Device (IED) and stores these measured values in internal registers for serial communication access.

The 120V ac input meters, with AC power supply option, meet IEC standard 1010 and are certified by Underwriters Laboratory to meet UL and CSA standards.

Features

- Multiple measurements with accuracy and fast response
- 3-Phase-at-once screens
- Automatic engineering unit display
- Demand/Min/Max values with local/remote reset
- Direct connect up to 480V ac
- RS-485, RS-232, Modbus Plus™ physical ports
- Modbus® RTU, DNP3, Modbus Plus protocol
- Analog Outputs (with optional AOC)
- Universal Power Supply option—a single supply that operates from 24, 48, 125, or 250V dc source or 115V ac service

Benefits to Design Engineers

- Precise and timely measurement of all needed parameters
- Easy to use and mount without expensive panel rework
- Simple connections for transmitting values to serial, analog or mixed systems.
- No post installation headaches with rugged, utility grade design
- Lowers purchase, installation and operating costs



MultiComm

Precise and Fast Measurements

The Bitronics MultiComm meter is a precise instrument for measuring multiple electrical parameters. True RMS measurements are standard and accommodate signals containing harmonics in both current and voltage inputs. This results in accurate measurements despite waveform distortions.

The instruments feature many per-phase measurements for phase-balance assessment.

The Bitronics MultiComm RTH models provide additional demand and harmonic measurements by digitally integrating instantaneous samples to obtain thermal demand and harmonic values. These demand values are used to record the minimum and maximum thermal demand values since last reset.

Accuracy

- 0.25% Accuracy Class
- Frequency Accuracy is +/- 0.01Hz
- True RMS Measurements include harmonics

Energy

- 0 to 99,999,999 kWh for Import and Export
- 0 to 99,999,999 kVARh for Import and Export
- Stored every 90 seconds in non-volatile memory (no batteries). Resettable from network

Frequency

- 45.00Hz to 75.00Hz measurement range

Real-Time Measurements

- All Voltage, Current, Power, Power Factor, Frequency, and Energy parameters calculated every 100ms for MultiComm RT or 150ms for MultiComm RTH
- All Harmonics, K-factor, Displacement Power Factor, and fundamental parameters calculated every 600ms

Measurements

Voltage Measurements

- True RMS L-N Voltage per Phase⁴
- True RMS L-L Voltage per Phase¹
- Fundamental Frequency

Current Measurements

- True RMS Amps per Phase
- Residual Neutral Current⁴

Power Measurements

- Watts per Phase⁴
- Total Three Phase Watts
- VARs per Phase⁴
- Total Three Phase VARs
- VA per Phase⁴
- Total Three Phase VA
- Power Factor per Phase⁴
- Total Three Phase Power Factor

Energy Measurements

- Kilowatt-hours, Import and Export
- KiloVAR-hours, Import and Export

Demand Min/Max Measurements

(RTH Models only)

- Present² and Peak Amp Demand per Phase
- Present² and Peak Residual Neutral Amp Demand⁴
- Present², Max and Min Volt Demand per Phase
- Present², Max and Min Total Watt Demand
- Present², Max and Min Total VAR Demand
- Present², Max and Min Total VA Demand

$$\% \text{ THD (Voltage)} = \frac{\sqrt{\sum_{h=2}^{31} V_h^2}}{V_1} \times 100\%$$

where V_1 = Fundamental component of line voltage

$$\% \text{ TDD (Current)} = \frac{\sqrt{\sum_{h=2}^{31} I_h^2}}{I_L} \times 100\%$$

where I_L = Maximum demand load current (user-programmable; if set to 0 then $I_L = I_1$ for % THD measurement)

Harmonic Measurements

(RTH Models only)

- Over 200 values: % TDD, % THD, Individual Harmonic, K-Factor, and Displacement Power Factor; includes many per phase and Peak values

Display Screens

All three phases of a measurement are displayed simultaneously for at-a-glance phase balance assessment.



The three top value displays and the lower engineering unit display form screens. The top three displays show 3-Phase values, total values, or unique combinations of values. The lower display automatically shows the appropriate engineering units for the displayed measurement.

Press and release the Select push-button to have the displayed screen remain fixed or to scroll through all enabled screens at 5-second intervals, which is ample time for effortless recording of measurements.

Holding the Select push-button causes a fast scroll of all screens at 1/2 -second intervals. Releasing the push-button will pause the displayed screen. In MultiComm RTH models, the Select push-button can also be used to reset the Demand Min/Max values.

Enable/Disable screens through configuration registers or from the front of the instrument with the face-plate removed.

- Three, 4-digit, high efficiency, 7-segment, 0.56" high, red LED displays
- Volts and Amps range of 0000 to 9999
- Watts, VARs, and VA range of -999 to 000 to 999
- PF range of -.000 to -.999 (Lag) and .000 to .999 (Lead)
- Fundamental frequency range of 45.00 to 75.00
- THD and TDD range of 000.0 to 999.9
- K-Factor range of 01.00 to 99.9

Engineering Unit Display

- One 8-character, 5x7 dot matrix, 0.20" high, red LED display

Select push-button:

Select display mode for enabled screens

- Fixed (toggle)
- Scroll (toggle)
- Fast Forward (hold)
- Demand Reset

¹ Calculated from L-N inputs on 4-Wire systems

² Present Demand values only available via network

⁴ 4-Wire systems only

Serial Transmission Options

Reduce wiring, terminations and input signal conditioning costs by transmitting the MultiComm measurements to other digital devices using serial data communications. The MultiComm family provides several serial options to interface with a wide variety of RTUs, PLCs, PCs, and other digital devices.

The Modbus Plus serial output option is a high-speed, high-capacity serial bus and protocol that is very suitable to real time distributed control and automation strategies. The RS-485 bus is well suited for a medium speed multiple instrument monitoring system and has excellent noise immunity.

The RS-232 allows for short interconnection with a broad range of digital devices. The RS-485 and the RS-232 serial ports can be equipped with either Modbus RTU or DNP3 protocol. This provides for five combinations of serial ports and protocols that forms "network connections."

Protocol Choices

- **Modbus Plus**, certified by Schneider Electric, supports: 64 user selectable addresses; Global Data, Read Holding Registers, and Preset Single/Multiple Registers for energy reset, demand reset, and scaling.
- **Modbus RTU Slave** supports: 247 user selectable addresses; Read Holding Registers, and Preset Single/Multiple Registers for energy reset, demand reset, and scaling.
- **DNP3 Slave** supports: 256 user selectable addresses; Read by class, object or point; and Direct Operate commands for energy reset, demand reset, and scaling. RTH models include a configuration register to limit the class 0 response.

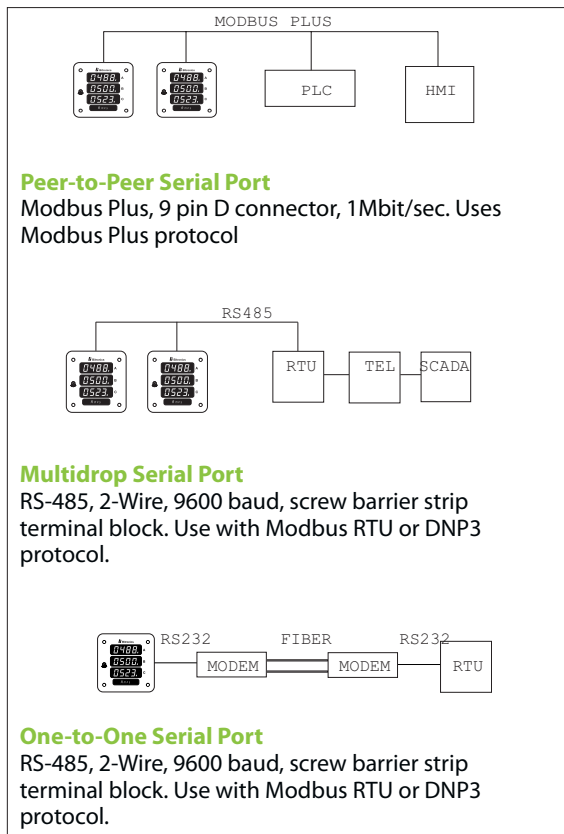

Peer-to-Peer Serial Port

Modbus Plus, 9 pin D connector, 1Mbit/sec. Uses Modbus Plus protocol

Multidrop Serial Port

RS-485, 2-Wire, 9600 baud, screw barrier strip terminal block. Use with Modbus RTU or DNP3 protocol.

One-to-One Serial Port

RS-485, 2-Wire, 9600 baud, screw barrier strip terminal block. Use with Modbus RTU or DNP3 protocol.

Analog Transmissions Options

Transmit the Bitronics MultiComm measurements to other devices using analog signals from a Bitronics Analog Output Converter (AOC). The AOC communicates with the MultiComm serial port using Modbus RTU or DNP3 protocol over an RS-485 bus, and then converts the register values to analog signals proportional to these measurements. Using a bus provides for several useful configurations. The RS-485 bus allows for configurations with multiple instruments with cable runs up to 4000 feet (1200M). This distributed architecture also allows Hybrid configurations for use with mixed analog and serial solutions.

Another useful feature of the distributed architecture is that the MultiComm instruments can continue to be used, at no additional costs, when later upgrading to a serial communications network.

The AOC is equipped with 8 analog outputs, using either 0 - 1mA or 4 - 20mA signals.

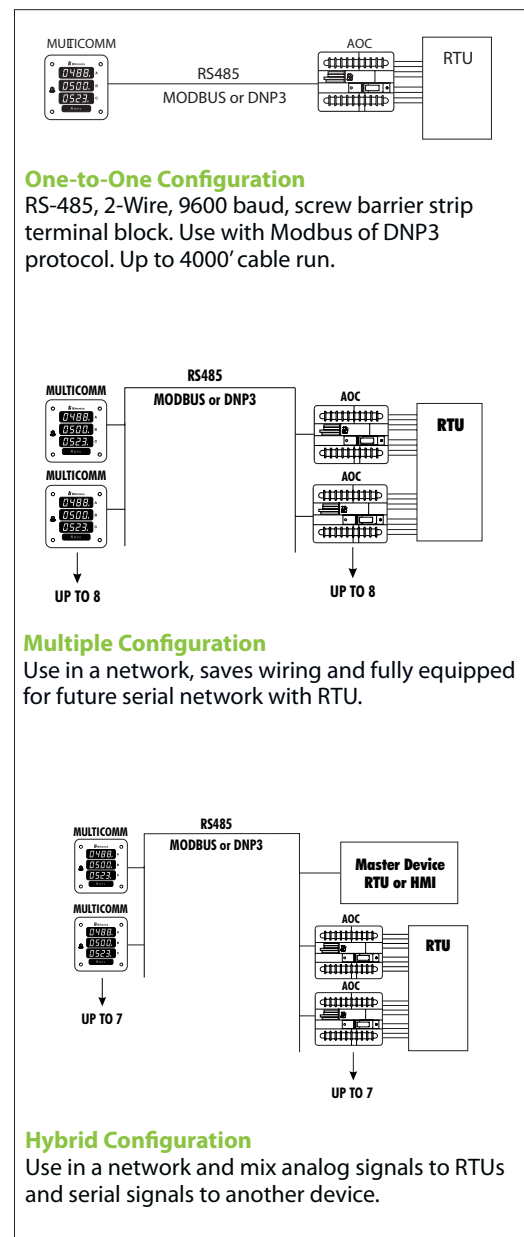

One-to-One Configuration

RS-485, 2-Wire, 9600 baud, screw barrier strip terminal block. Use with Modbus or DNP3 protocol. Up to 4000' cable run.

Multiple Configuration

Use in a network, saves wiring and fully equipped for future serial network with RTU.

Hybrid Configuration

Use in a network and mix analog signals to RTUs and serial signals to another device.

Easy Installation

The Bitronics MultiComm instruments are designed to make installation and maintenance a snap. They are loaded with features such as the 4" round metal can design with large stud terminals, wide temperature range, displayable self-test diagnostic codes, and front access for configuration and service. All MultiComm models are available with the universal power supply which can operate from a wide variety of DC or AC sources.

Beneath the faceplate is everything that is needed to configure the instrument. Just flip the CT Set/PT Set Switch up or down and the CT or PT built-in library is available by the Select Push-button Switch. Upon return of the CT Set/PT Set Switch you can select the Enable/Disable Screen mode. Just read the bottom display and select what screen to enable.

For RTH models you can also enable or disable the local reset feature. These configuration settings can also be set through the serial port.

Auxiliary Power

Three power supply options:

- 115V ac
- 230V ac
- Universal AC/DC supply: 55 - 200V ac or 20 - 280V dc

BiView Utility Software

Setup and evaluation software is available:

- View all register values
- Write CT & PT ratios
- Reset energy/demand
- Enable/disable screens

Environment

- -30°C to 70°C operating temperature
- 2500V ac isolation to case
- 1500V ac minimum isolation input to output
- Meets IEEE/ANSI C37.90 Surge Withstand
- Meter with AC only power supply and 120V ac input meets IEC standard 1010 and UL certified to meet UL3111-1 and CAN/CSA C22.2NO 1010.1-02 standards. UL file #E164178

Bitronics MultiComm with faceplate removed

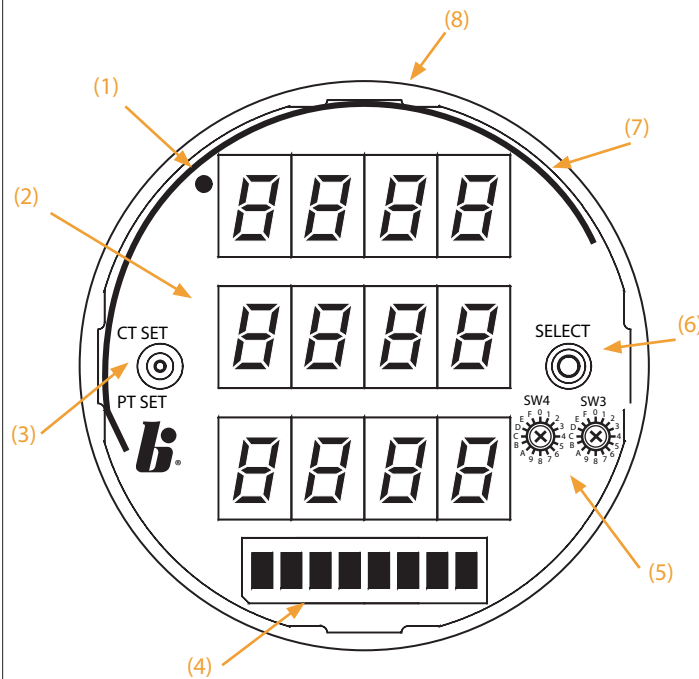

- (1) MultiComm diagnostic LED. LED provides communication status.
- (2) Locally displayed self diagnostic messages. Available as register via serial port.
- (3) CT Set / PT Set Switch
 - CT ratio set mode
 - PT ratio set mode
 - Screen / Local reset set mode
- (4) Engineering unit display will also show modes.
 - CT ratio set mode
 - PT ratio set mode
 - Screen - enable / disable
 - Local reset - enable / disable
- (5) MultiComm address switches
- (6) Select Push-button Switch (redundant to faceplate switch) will also select
 - Select CT ratio
 - Select PT ratio
 - Enable / disable screens
 - Enable / disable local reset
- (7) Bail wire for front removable of electronics module while still in service.
- (8) Fits standard 4" round switchboard cutout.

Current Inputs

All Bitronics MultiComm instruments

Supports the use of Current transformers (CT). These connections are made to internal transformers to provide excellent, utility grade isolation.

The field selectable, built-in ANSI library of CT turns ratios makes scaling easy to set and change. Custom ratios can be used by writing them into the instrument through the serial port. The graphic shows a wiring schematic for a 3-Wire system. The MultiComm family also supports 4-Wire systems.

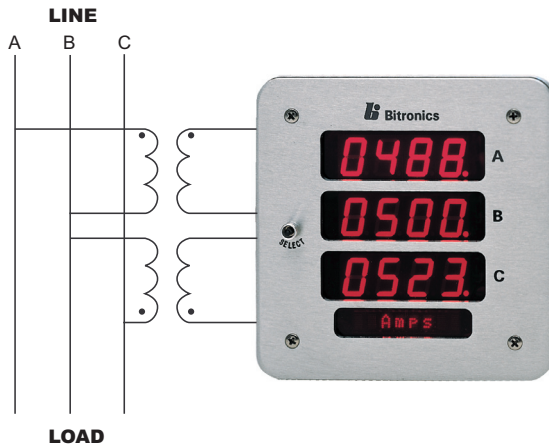

MultiComm RT and MultiComm RTH

- 120V ac nominal, range 0 - 150V ac
- 50Hz or 60Hz nominal frequency
- Signal burden <1mA at 120V ac (0.1 VA)

Voltage Inputs

Bitronics MultiComm RT C and Bitronics MultiComm RTH C instruments

Supports the direct connection of up to 480V ac L-L nominal for low voltage applications. These connections are made to internal transformers and continue to provide excellent utility grade isolation. Scaling is fixed for the appropriate voltage input range.

The graphic shows a wiring schematic for a 3-Wire system. The MultiComm family also supports 4-Wire systems.

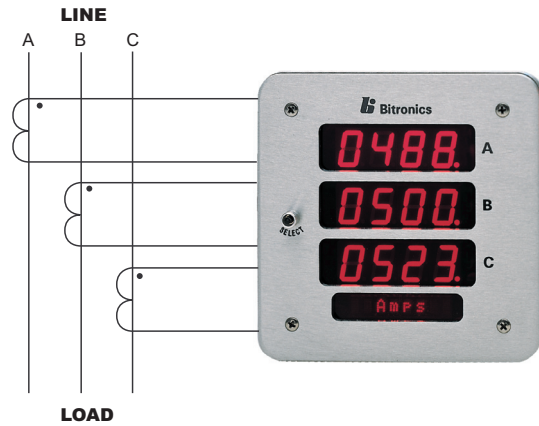

All MultiComm

- 5A ac nominal, range 0 to 10A ac
- Optional 1A ac nominal, range 0 to 2A ac
- 50Hz or 60Hz nominal frequency
- Signal burden 4mV at 5A ac (0.02VA)

Voltage Inputs

Bitronics MultiComm RT and Bitronics MultiComm RTH instruments

Supports the use of Potential transformers (PT) or Voltage transformers (VT) for high voltage applications. These connections are made to internal transformers to provide excellent utility grade isolation.

The field selectable built-in ANSI library of PT or VT turns ratios makes scaling easy to set and change. Custom ratios can be used by writing them into the instrument through the serial port. The graphic shows a wiring schematic for a 3-Wire system. The MultiComm family also supports 4-Wire systems.

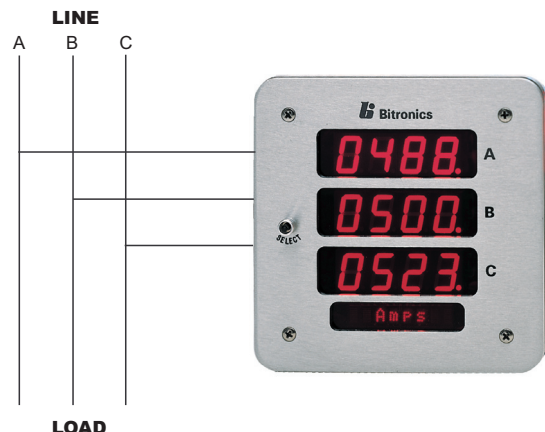

MultiComm RT C and MultiComm RTH C

- The V12 option is used for 240 / 208 L-L ac nominal, 3-Wire systems, range 0-300V ac.
- The V13 option is used for 277 L-N ac nominal, 4-Wire systems, range 0-375V ac.
- The V14 option is used for 480 L-L ac nominal, 3-Wire systems, range 0-540V ac.
- For direct connection to 120V ac systems, use the standard MultiComm instruments with the 1:1 PT ratio.
- 50Hz or 60Hz nominal frequency
- Signal burden <1.2mA at 480V ac (0.6 VA)

Select Models

- **Bitronics MultiComm RT**

2, 2½ or 3-Elements / Models: MTWIE2B, MTWIE3B, or MTWIE1B

RS-232 or RS-485/ Modbus RTU or DNP3

See Order Guide 122

- **Bitronics MultiComm RT Modbus Plus**

2, 2½ or 3-Elements / Models: MTWIE5B, MTWIE6B, or MTWIE4B

See Order Guide 124

- **Bitronics MultiComm RT C**

2 or 3-Elements / Models: MTWIEC2B, MTWIEC1B, MTWIEC5B or MTWIEC4B

RS-232 or RS-485/Modbus RTU or DNP3; or Modbus Plus

See Order Guide 126

- **Bitronics MultiComm RTH**

2, 2½ or 3-Elements / Models: MTWDE2B, MTWDE3B, or MTWDE1B

RS-232 or RS-485/ Modbus RTU or DNP3

See Order Guide 123

- **Bitronics MultiComm RTH Modbus Plus**

2, 2½ or 3-Elements / Models: MTWDE5B, MTWDE6B, or MTWDE4B

See Order Guide 125

- **Bitronics MultiComm RTH C**

2 or 3-Elements / Models: MTWDEC2B, MTWDEC1B, MTWDEC5B, or MTWDEC4B

RS-232 or RS-485/Modbus RTU or DNP3; or Modbus Plus

See Order Guide 127

Accessories

- **Analog Output Converter**

0 - 1mA, 4 - 20mA / Models: NAO8101 or NAO8102; NAO8103 or NAO8104

RS-485/Modbus RTU; RS-485/DNP3

- **BiView**

Setup and evaluation software



Bitronics® MultiComm™
Digital Power Meter



2-Element power meter for 3-Wire systems

2½ or 3-Element power meter for 4-Wire systems



Copyright © 2010 NovaTech, LLC. All rights reserved. All brand and product names mentioned in this document are trademarks of their respective owners. NovaTech and Bitronics are registered trademarks of NovaTech, LLC. The information in this literature is subject to change without notice and is not to be construed as a warranty.

BR_MultiComm_102010

Contact:

NovaTech, LLC

Bitronics Measurement and Recording

261 Brodhead Road

Bethlehem, PA 18017

T: 610.997.5100

F: 610.997.5450

E: bitronics@novatechweb.com

www.novatechweb.com

NovaTech®
Bitronics ♦ D/3 ♦ Orion

MultiComm™